

**FIDDLER'S CREEK
COMMUNITY DEVELOPMENT
DISTRICT #1**

March 23, 2022

**BOARD OF SUPERVISORS
PUBLIC HEARING AND
REGULAR MEETING
AGENDA**

Fiddler's Creek Community Development District #1

OFFICE OF THE DISTRICT MANAGER

2300 Glades Road, Suite 410W • Boca Raton, Florida 33431

Phone: (561) 571-0010 • Fax: (561) 571-0013 • Toll-free: (877) 276-0889

March 16, 2022

Board of Supervisors
Fiddler's Creek Community Development District #1

ATTENDEES:
Please identify yourself each time you speak to facilitate accurate transcription of meeting minutes.

Dear Board Members:

The Board of Supervisors of the Fiddler's Creek Community Development District #1 will hold a Public Hearing and Regular Meeting on March 23, 2022 at 8:00 a.m., at the Fiddler's Creek Club and Spa, 3470 Club Center Boulevard, Naples, Florida 34114. Members of the public may listen to and participate in the meeting via conference call at **1-888-354-0094**, Participant Passcode: **709 724 7992**. The agenda is as follows:

1. Call to Order/Roll Call
2. Public Comments: Non-Agenda Items (*3 minutes per speaker*)
3. Quality Control Lake Report - March, 2022: *SOLitude Lake Management*
 - Update: Lake 34A
4. Health, Safety and Environment Report
 - A. Irrigation and Pressure Cleaning Efforts: *Todd Lux*
 - B. Security and Safety Update: *Ed Jasiiecki*
5. Developer's Report
6. Engineer's Report: *Hole Montes, Inc.*
7. Continued Discussion: Preemptive Actions to Prevent Further Damage Between Valley Gutters and Sidewalks Caused by Trees in Affected Areas
8. Public Hearing to Hear Public Comments and Objections to the Adoption of Amendments to the District's Rule Regarding Sidewalk Maintenance Responsibility ("Sidewalk Rule"), Pursuant to Sections 190.11(5), 190.011(15) and 190.035, Florida Statutes
 - A. Affidavits of Publication

- Notice of Rule Development
 - Notice of Rulemaking
- B. Consideration of Resolution 2022-05, Adopting Amendments to the Rule Regarding Sidewalk Maintenance Responsibilities
9. Discussion: FDOT Traffic Signal Warrant Analysis for SR 951 (Collier Boulevard) at Championship Drive
10. Continued Discussion: Engagement of Outside Counsel for Mediation with Regard to US 41 Traffic Signal Agreement
- Attorney Pat White
11. Update: Status of Petition for Boundary Amendment
12. Update: Meeting with LandCare Regarding Landscape Issues
13. Acceptance of Unaudited Financial Statements as of February 28, 2022
14. Approval of February 23, 2022 Regular Meeting Minutes
15. Action/Agenda or Completed Items
16. Staff Reports
- A. District Counsel: *Woodward, Pires and Lombardo, P.A.*
- B. District Manager: *Wrathell, Hunt and Associates, LLC*
- NEXT MEETING DATE: April 27, 2022 at 8:00 A.M.
- QUORUM CHECK
- | | | | | | | |
|--------------------|--------------------------|-----------|--------------------------|-------|--------------------------|----|
| Joseph Badessa | <input type="checkbox"/> | IN PERSON | <input type="checkbox"/> | PHONE | <input type="checkbox"/> | NO |
| Torben Christensen | <input type="checkbox"/> | IN PERSON | <input type="checkbox"/> | PHONE | <input type="checkbox"/> | NO |
| Joseph Schmitt | <input type="checkbox"/> | IN PERSON | <input type="checkbox"/> | PHONE | <input type="checkbox"/> | NO |
| Robert Slater | <input type="checkbox"/> | IN PERSON | <input type="checkbox"/> | PHONE | <input type="checkbox"/> | NO |
| Frank Weinberg | <input type="checkbox"/> | IN PERSON | <input type="checkbox"/> | PHONE | <input type="checkbox"/> | NO |
- C. Operations Manager: *Wrathell, Hunt and Associates, LLC*
17. Supervisors' Requests
18. Public Comments

19. Adjournment

Should you have any questions, please do not hesitate to contact me directly at 239-464-7114.

Sincerely,



Chesley E. Adams, Jr.
District Manager

FOR BOARD MEMBERS AND STAFF TO ATTEND BY TELEPHONE

CALL IN NUMBER: 1-888-354-0094

PARTICIPANT PASSCODE: 709 724 7992

FIDDLER'S CREEK
COMMUNITY DEVELOPMENT DISTRICT
#1

3

FIDDLER'S CREEK CDD #1 Quality Control Lake Report

#	Inspection Date	Action Items Observed	*Treatment Date	*Target
Group A				
1	3/8/2022	Tg, Vi, Ct spot treat growth	3/17/2022	Tg, Vi, Ct
2	3/8/2022			
3	3/8/2022			
4	3/8/2022	SFA, and CFH	3/17/2022	SFA, CFH
4A	3/8/2022			
5	3/8/2022			
6	3/8/2022	Tg behind homes on south side, growth was fairly minimal	3/17/2022	Tg
7	3/8/2022	Spot treat one area of growth on SE bank	3/17/2022	Tg
7A	3/8/2022	Spot treat one are of growth in NE corner	3/17/2022	Tg
8	3/8/2022	Tg, and Ct around perimeter	3/17/2022	Tg, Ct
9	3/8/2022	Narrow band of SFA, and grasses need to be sprayed growing along golf course	3/17/2022	Tg, Ct, SFA
10	3/8/2022			
95	3/8/2022	Melaleuca in littoral shelf	3/17/2022	Melaleuca
FC-1	3/8/2022			
FC-3	3/8/2022			

* Treatment dates and targets are susceptible to change due to site conditions: wind, rain, flooding etc.

Abbreviation Key									
Alligator Weed	Aw	Chara	Ch	Illinois Pondweed	Pi	Southern Naiad	Ns	Water Hyacinth	Wh
Bottom Algae	Ba	Crested Floating Heart	CFH	Pennywort	Pw	Surface Filamentous Algae	Sfa	Water Lettuce	WL
Bulrush	Bul	Duckweed	Dw	Primrose	Pr	Torpedograss	Tg		
Cattails	Ct	Hydrilla	H	Planktonic Algae	Pa	Vines	Vi		

FIDDLER'S CREEK CDD #1
Quality Control Lake Report



FIDDLER'S CREEK CDD #1
Quality Control Lake Report

#	Re-Evaluation	Action Items Observed	Completed
Group C			
37 A/B	March 2022	Spot treat new bulrush growth in N end off fairway. Spot treat Tg between the hole 7 green and hole 8 tee.	Grasses remain, gator was sighted, re-treat 3/17/2022
38 A/B/C	March 2022	Treatment in progress for Tg, and Vi, shoreline weeds show discoloration from treatment and are dying back	Yes
40 A/B	March 2022	Continue to treat Aw on the littoral shelf. Treatment in progress for chara.	Chara shows damage from previous treatments but requires follow up, re-treat 3/17/2022
42 A/B	March 2022	Treatment in progress for shoreline weeds and algae	Algae appears less severe but is still present, littoral shelf requires additional treatment for grasses and vines, re-treat 3/17/2022
50B	March 2022	Pi beginning to accumulate along shore	Yes, Pi is thinner and less severe
50A	March 2022	Spot treat Wh and Wl along hole 12, traces of Pi noted as well	Yes, however new CFH growth was observed
70A	March 2022	Spot treat Vi	Very little vines remain, spot treat remaining, re-treat 3/17/2022
79A	March 2022	Spot treat Vi	Treat grasses, brush, and vines during routine maintenance, re-treat 3/17/2022

* This portion will be completed the month following the initial inspection when the action items were identified to ensure compliance*

* Treatment dates and targets are susceptible to change due to site conditions: wind, rain, flooding etc

FIDDLER'S CREEK CDD #1
Quality Control Lake Report



FIDDLER'S CREEK
COMMUNITY DEVELOPMENT DISTRICT
#1

4A

CDD I

03/23/2022

TODD LUX, DIRECTOR OF FACILITIES

CDD I CONTRACTED RESPONSIBILITIES

- Tree Canopy Trimming
- Pressure Washing
 - Pressurewashing@Fiddlerscreek.com
- Irrigation
 - IrrigationUsers@Fiddlerscreek.com

TREE CANOPY TRIMMING



“Fruited Palms” :

- Completing during March
 - ✓ 2nd trimming will occur again in October
- April- Hardwoods

PRESSURE WASHING



Past 30 Days:

- Marsh Cove Communities
- Isla Del Sol

Projected Next 30 Days:

- Championship Drive Delivery of New Clean Machine

Future:

- Amador and Surrounding Communities

Current Month's Projected Plan

- Completed
- Current Month Progress
- Scheduled Routes
- Other Pressure Cleanings

2022 Mapping





Questions?



FIDDLER'S CREEK
COMMUNITY DEVELOPMENT DISTRICT
#1

4B

Gate Access Control

- Call the automated gate house at 239-529-4139
- Enter your guest information on the member's website
- Use the Fiddler's Creek mobile app to register guests
- IF YOU EXPERIENCE DIFFICULTY WITH ANY OF THESE, PLEASE SEND THE INFORMATION TO safety@fiddlerscreek.com, ALWAYS INCLUDE YOUR NAME AND ADDRESS.
- **Community Patrol 239-919-3705**

**WE ARE NOT FIRST RESPONDERS, ALWAYS CALL 911 FOR
AN EMERGENCY
THEN CALL COMMUNITY PATROL TO INFORM THEM OF
THE INCIDENT**

GATEHOUSE ACCESS CONTROL-FEBRUARY 2022

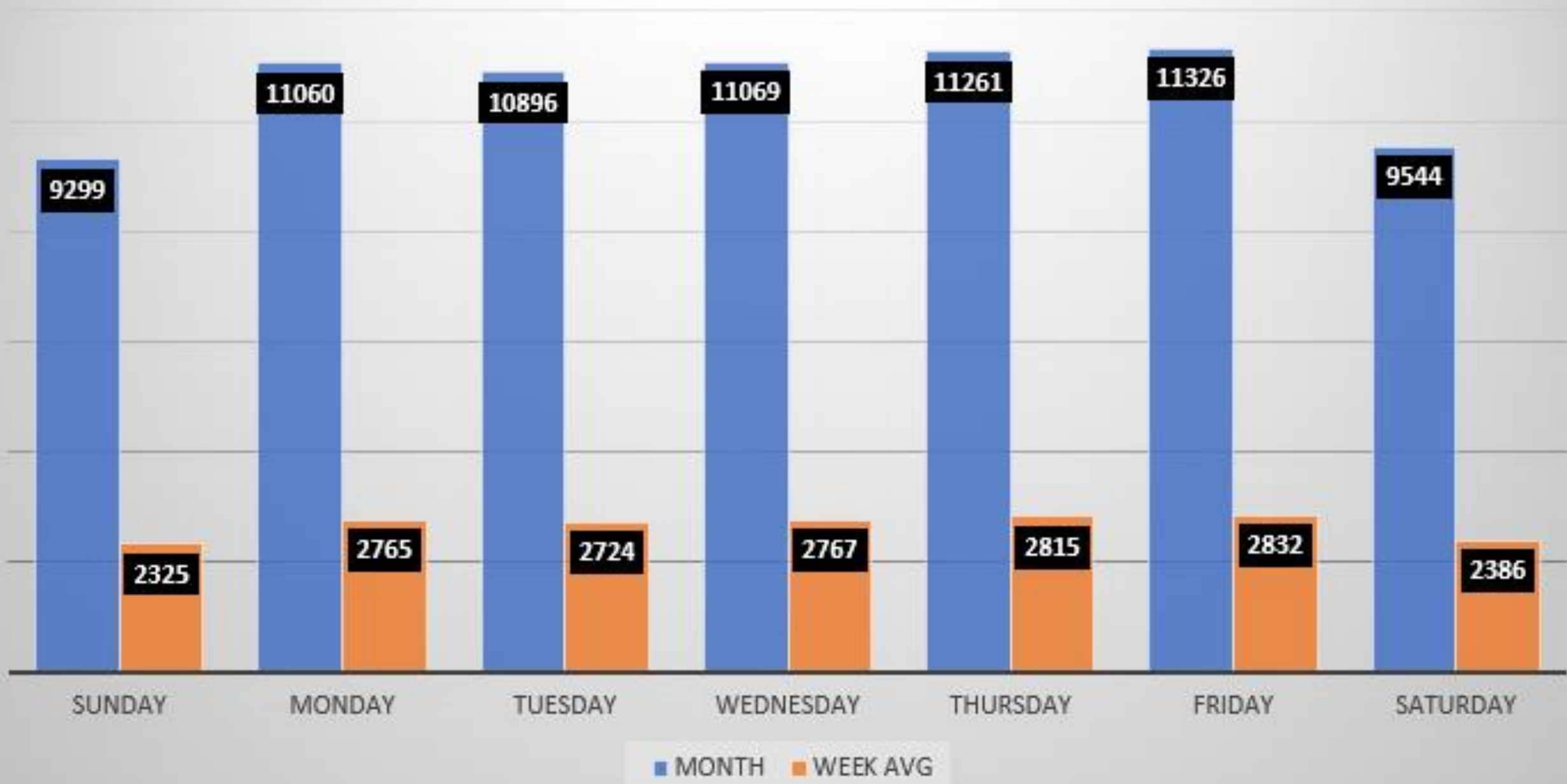

OCCUPANCY REPORT-2022

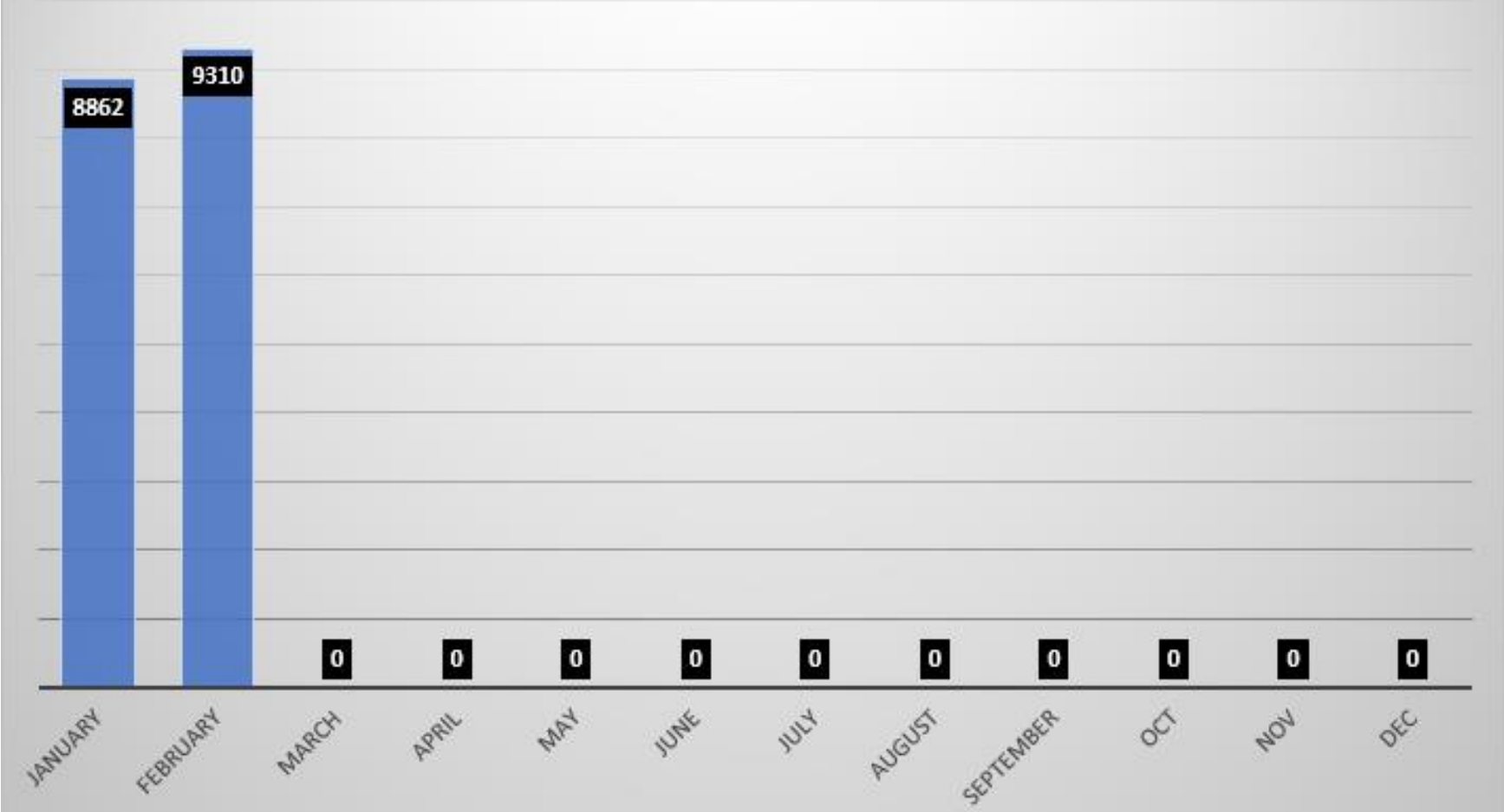

■ 2022

Occupancy Report - FEBRUARY 2022

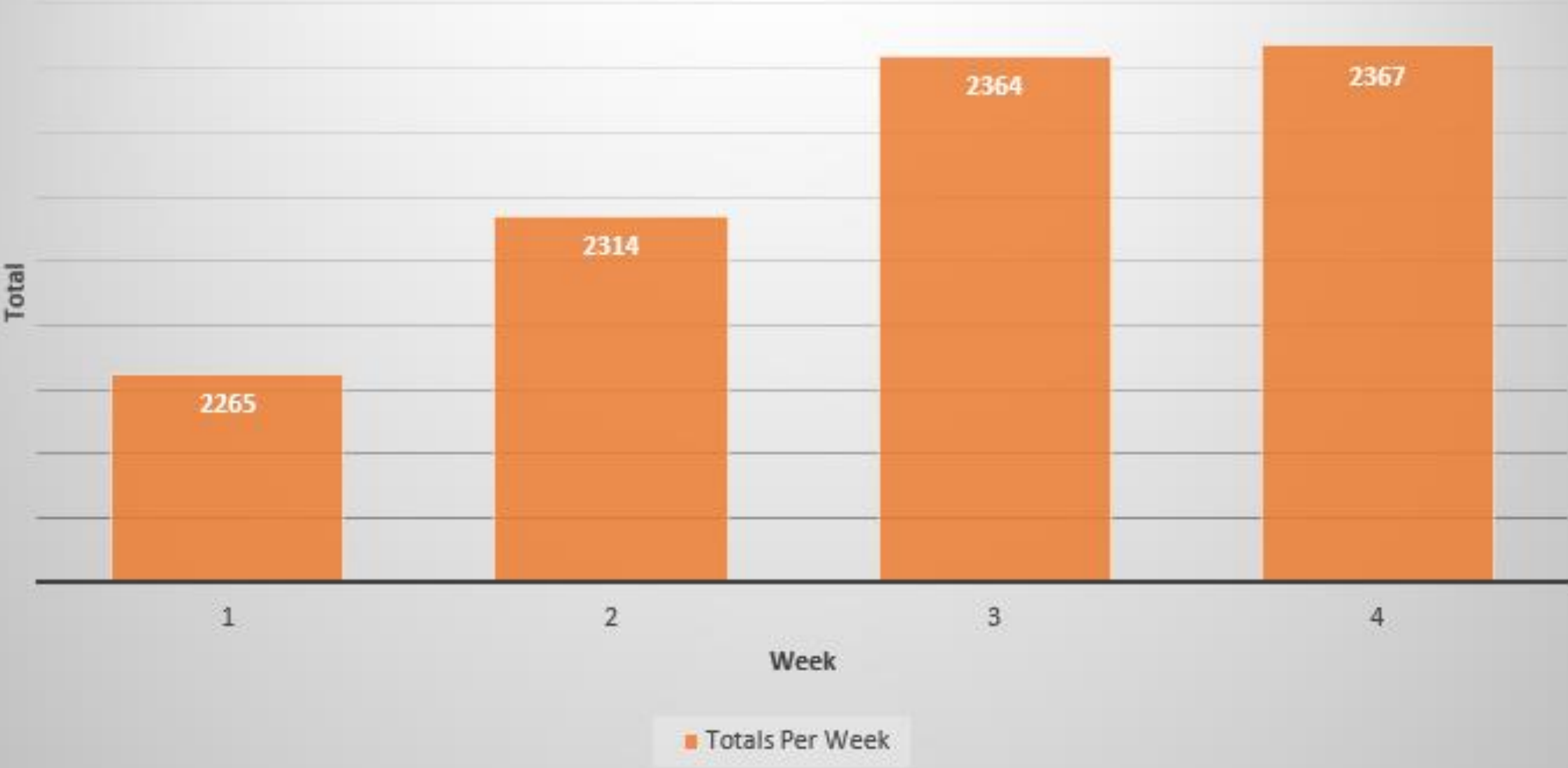

INCIDENTS-JANUARY-FEBRUARY 2022

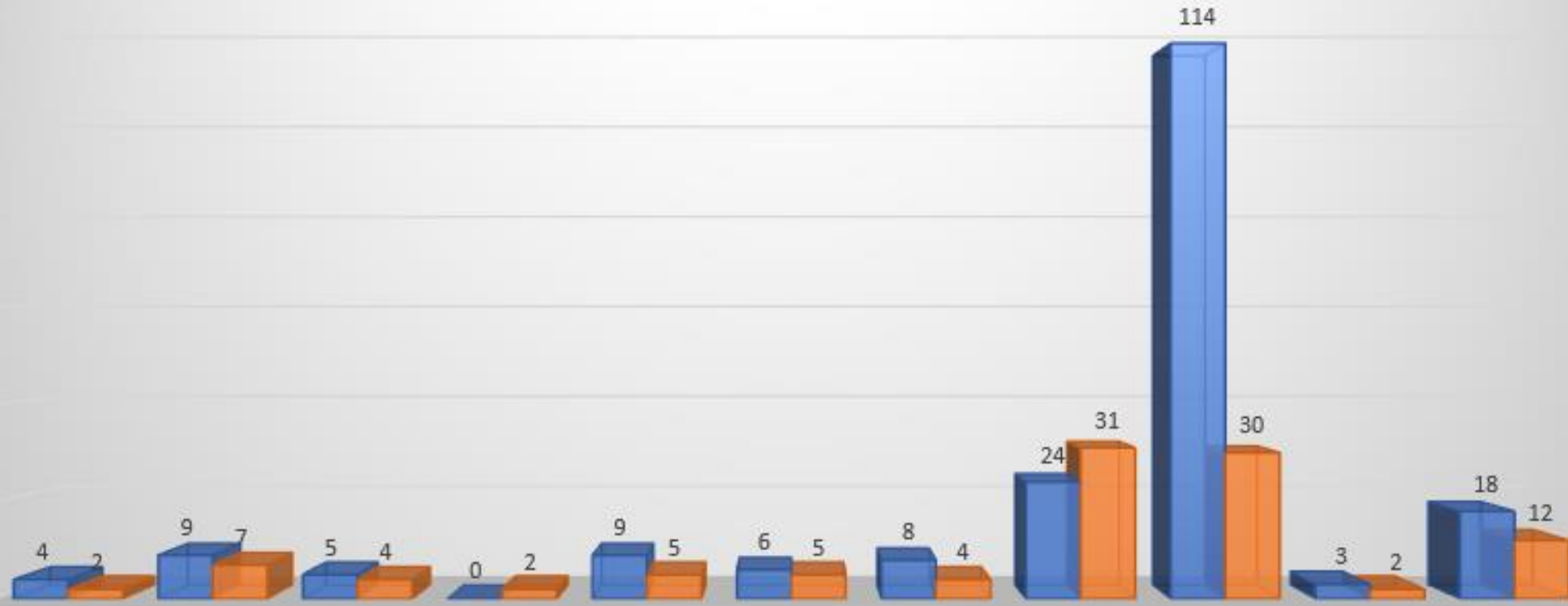

	Alarms	Animal Complaints	By-Law Violations	Gate Arm Damage	Medicals	Noise Complaints	Officer Observation	Open Garage Doors	Parking	Property Damage	Resident Complaints
■ FEBRUARY	4	9	5	0	9	6	8	24	114	3	18
■ JANUARY	2	7	4	2	5	5	4	31	30	2	12

FIDDLER'S CREEK
COMMUNITY DEVELOPMENT DISTRICT
#1

8A

Miscellaneous Notices



Published in Naples Daily News on January 6, 2022

Location

Collier County, Florida

Notice Text

NOTICE OF RULE DEVELOPMENT BY FIDDLER'S CREEK COMMUNITY DEVELOPMENT DISTRICT #1 In accord with Chapters 190 and 120, Florida Statutes, the Fiddler's Creek Community Development District #1 ("District") hereby gives notice of its intention to develop amendments to its Rule Regarding Sidewalk Maintenance Responsibility ("Rule"), outlining additional responsibilities of property owners under certain circumstances to remediate or to pay a charge for inspection and remediation of damage to District facilities or improvements, located within District right-of-way ("ROW") or easement(s), from tree roots encroaching into a District ROW or easement(s)). This proposed amendment to the Rule will outline the responsibilities and obligations of an abutting property owner in such circumstances to remediate or to pay a charge for inspection and remediation if the property owner fails to engage in required remediation and repair activity within a reasonable period of time after receipt of written notice. The purpose and effect of the proposed amendment to the Rule is to provide for efficient and effective operations of the District. Specific legal authority for the amendment to the Rule includes, but is not limited to, Sections 190.011(5), 190.012, 120.54, and 120.81, Florida Statutes (2021). A copy of the preliminary text of the proposed amendment to the Rule, once available, may be obtained by contacting the District Manager at 2300 Glades Road, Suite 410W; Boca Raton, FL 33431, Phone: (561) 571-0010; Fax: (561) 571-0013; or by calling toll-free (877) 276-0889. District Manager Fiddler's Creek Community Development District #1 Pub: Jan 6, 2022 #5070979

Naples Daily News

PART OF THE USA TODAY NETWORK

Published Daily
Naples, FL 34110

FIDDLERS CREEK I CDD
2300 GLADES RD 410 W

BOCA RATON, FL 33431

Affidavit of Publication

STATE OF WISCONSIN
COUNTY OF BROWN

Before the undersigned they serve as the authority, personally appeared said legal clerk who on oath says that he/she serves as **Legal Clerk** of the Naples Daily News, a daily newspaper published at Naples, in Collier County, Florida; distributed in Collier and Lee counties of Florida; that the attached copy of the advertising was published in said newspaper on dates listed. Affiant further says that the said Naples Daily News is a newspaper published at Naples, in said Collier County, Florida, and that the said newspaper has heretofore been continuously published in said

Collier County, Florida; distributed in Collier and Lee counties of Florida, each day and has been entered as second class mail matter at the post office in Naples, in said Collier County, Florida, for a period of one year next preceding the first publication of the attached copy of advertisement; and affiant further says that he has neither paid nor promised any person, or corporation any discount, rebate, commission or refund for the purpose of securing this advertisement for publication in said newspaper issue(s) dated or by publication on the newspaper's website, if authorized, on

Issue(s) dated: 02/01/2022

Subscribed and sworn to before on February 1, 2022:

Notary, State of WI, County of Brown

NOTICE OF RULEMAKING AND PUBLIC HEARING REGARDING AMENDING THE RULES OF THE FIDDLER'S CREEK COMMUNITY DEVELOPMENT DISTRICT #1 [DISTRICT] TO ADOPT AMENDMENTS TO THE DISTRICT RULE REGARDING SIDEWALK MAINTENANCE RESPONSIBILITY

A public hearing will be conducted by the Board of Supervisors of the Fiddler's Creek Community Development District #1 ("District") on March 23, 2022 at 8:00 a.m., at the Fiddler's Creek Club and Spa, 3470 Club Center Boulevard, Naples, Florida 34114, for the purpose of hearing and considering and adopting amendments ("Amendments") to the District's Rule Regarding Sidewalk Maintenance Responsibility ("Sidewalk Rule"), outlining additional responsibilities of property owners under certain circumstances to remediate or to pay a charge for inspection and remediation of damage to District facilities or improvements, located within District right-of-way ("ROW") or easement(s), from tree roots encroaching into a District ROW or easement(s). In accord with Chapters 120 and 190, Florida Statutes, the District hereby gives the public notice of its intent to adopt its proposed Amendments to its Sidewalk Rule. Prior notice of rule development was published in the Naples Daily News on January 6, 2022. The purpose of the Amendments to the Sidewalk Rule is to provide for rules outlining the responsibilities of property owners with trees that have tree roots encroaching into a District right of way (ROW) or easement, resulting in or causing the upheaval or sinking of a sidewalk within the District ROW or easement or resulting in damage to District facilities or improvements.

Specific legal authority for the adoption of the proposed Amendments to the Sidewalk Rule includes but is not limited to Sections 190.011(5), 190.012, 120.54, and 120.81, Florida Statutes (2021). The specific laws implemented in the Amendments to the Sidewalk Rule include but are not limited to Sections 190.011(5), 190.012, Florida Statutes (2021).

A copy of the proposed Amendments to the Sidewalk Rule may be obtained by contacting the District Manager at c/o Wrathell, Hunt & Associates, LLC, 2300 Glades Road, Suite 410W, Boca Raton, Florida 33431, Ph: (561) 571-0010; Fax: (561) 571-0013; or by calling toll-free (877) 276-0889 ("District Manager's Office").

Any person who wishes to provide the District with a proposal for a lower cost regulatory alternative as provided by Section 120.541(1), Florida Statutes, must do so in writing within twenty one (21) days after publication of this notice to the District Manager's Office.

This public hearing may be continued to a date, time, and place to be specified on the record at the hearing without additional notice. If anyone chooses to appeal any decision of the Board with respect to any matter considered at a public hearing such person will need a record of the proceedings and should accordingly ensure that a verbatim record of the proceedings is made which includes the testimony and evidence upon which such appeal is to be based. At the hearing, staff or Supervisors may participate in the public hearing by speaker telephone.

Pursuant to the provisions of the Americans with Disabilities Act, any person requiring special accommodations at this meeting because of a disability or physical impairment should contact the District Manager's Office at least forty-eight (48) hours prior to the meeting. If you are hearing or speech impaired, please contact the Florida Relay Service at 1-800-955-8771 or 1-800-955-8770 for aid in contacting the District Manager's Office.

Chesley E. Adams, Jr., District Manager
Fiddler's Creek Community Development District #1
Pub: Feb 1, 2022 #5110531

979.25

Publication Cost, \$41.00

Ad No: 0005110531

Customer No: 1304990

PO #:

of Affidavits 1

This is not an invoice

VICKY FELTY
Notary Public
State of Wisconsin

FIDDLER'S CREEK
COMMUNITY DEVELOPMENT DISTRICT
#1

8B

RESOLUTION NUMBER 2022-05

RESOLUTION OF THE BOARD OF SUPERVISORS OF THE FIDDLER’S CREEK COMMUNITY DEVELOPMENT DISTRICT #1 ADOPTING AMENDMENTS TO THE RULE REGARDING SIDEWALK MAINTENANCE RESPONSIBILITIES

Whereas, the Fiddler’s Creek Community Development District #1 (“District”) is a community development district, established in 1996 by Chapter 42X, Florida Administrative Code, as amended by the Florida Land and Water Adjudicatory Commission pursuant to the provisions of Chapter 190, Florida Statutes; and,

Whereas, on October 28, 2020 the Board held a duly noticed and properly advertised public hearing and heard and considered the adoption of a Rule titled “Sidewalk Maintenance Responsibilities”; and,

Whereas, on October 28, 2020 the Board heard and considered comments on the proposed Rule titled “Sidewalk Maintenance Responsibilities” and thereafter the Board adopted its Resolution No. 2021 - 01 to memorialize the adoption and approval of the Rule titled “Sidewalk Maintenance Responsibilities”; and,

Whereas, the Board desires to amend the Rule titled “Sidewalk Maintenance Responsibilities” through the adoption of this Resolution.

NOW, THEREFORE BE IT RESOLVED BY THE BOARD OF SUPERVISORS OF THE FIDDLER’S CREEK COMMUNITY DEVELOPMENT DISTRICT #1, THAT

1. The Rule titled “Sidewalk Maintenance Responsibilities” is amended in the manner outlined on the attached Amendment, **Exhibit "A"**, and said Amendment is hereby adopted and approved.
2. The District Manager is directed to file and maintain a clean version of the amended Rule titled “Sidewalk Maintenance Responsibilities” in the records of the District.
3. This Resolution and the amended Rule titled “Sidewalk Maintenance Responsibilities” are effective as of the date of adoption.

DULY PASSED AND ADOPTED this 23rd day of March, 2022.

BOARD OF SUPERVISORS OF THE
FIDDLER’S CREEK COMMUNITY
DEVELOPMENT DISTRICT #1

ATTEST:

Secretary

By: _____
_____, Its Chairman

FIDDLER'S CREEK
COMMUNITY DEVELOPMENT DISTRICT
#1

9

TRAFFIC SIGNAL WARRANT ANALYSIS

SR 951 (Collier Boulevard) at Championship Drive
Section 03030 - MP 7.578
Collier County

Prepared for:

THE FLORIDA DEPARTMENT OF TRANSPORTATION DISTRICT 1 TRAFFIC OPERATIONS

801 North Broadway Avenue
Bartow, FL 33830



Districtwide Contract for Traffic Operations
Financial Project ID: 198346-1-32-05
Contract No.: C-9V53
Burgess & Niple, Inc Contract No.: FDOT0031
Task Work Order: 119

Prepared by:

Burgess & Niple, Inc.

10006 N. Dale Mabry Hwy, Suite 201
Tampa, FL 33618

May 2021

Professional Engineer Daniel Hendrickson, PE, PTOE
P.E. Number: 76184

SIGNATURE PAGE
PROFESSIONAL ENGINEER'S SEAL

Burgess & Niple, Inc.
10006 N. Dale Mabry Highway, Suite 201
Tampa, Florida 33618-4422
813.962.8689

Engineer in Responsible Charge: Daniel Hendrickson, P.E.

Professional Registration No.: 76184

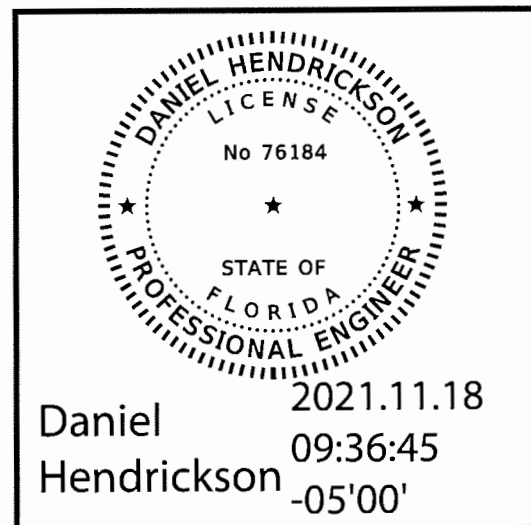

SIGN / DATE / SEAL

EXECUTIVE SUMMARY

The Florida Department of Transportation (FDOT) has retained Burgess & Niple Inc. (B&N) to conduct a Traffic Signal Warrant Analysis at the intersection of SR 951 (Collier Blvd) at Championship Dr in Collier County, Florida. The study has been conducted in accordance with the latest versions of the FDOT Manual on Uniform Traffic Studies (MUTS) and the Manual on Uniform Traffic Control Devices (MUTCD). Based on the results of the data collection, data analysis, field observations, and engineering judgment, the following conclusion was developed:

- This intersection meets Warrant 1 (8-hour volume) and Warrant 2 (4-hour volume) as listed in the Manual on Uniform Traffic Control Devices (MUTCD 2009).

INTRODUCTION

The Florida Department of Transportation (FDOT) has retained Burgess & Niple, Inc. (B&N) to conduct a Traffic Signal Warrant Analysis at the intersection of SR 951(Collier Blvd) and Championship Dr in Collier County, Florida. SR 951 extends north and south from the intersection and Championship Dr extends east from the intersection. The study has been conducted in accordance with the latest versions of the FDOT Manual on Uniform Traffic Studies (MUTS) and the Manual on Uniform Traffic Control Devices (MUTCD).

Figure 1: Project Location Map



Source: Google Maps

EXISTING CONDITIONS

The study intersection is outside Bonita Springs in unincorporated Collier County, Florida. **Table 1** below summarizes the existing conditions at this intersection and a Condition Diagram is provided on **Figure 2**. Pictures of the intersection are included within the Appendix.

Table 1: Summary of Existing Conditions

Feature	Description	
Major Street	SR 951 (Collier Blvd)	
Minor Street	Championship Dr	
Area Location	Collier County, Florida	
Surrounding Development	SR 951 (Collier Blvd) – Residential and undeveloped Championship Dr – Primarily residential	
Land Uses at the Intersection	Northwest – Undeveloped Southwest – Undeveloped	Northeast – Residential development Southeast – Driving range
Pedestrian Generators	Surrounding residential properties	
Traffic Control	SR 951 (Collier Blvd) – Uncontrolled Championship Dr – STOP control	
Posted Speed Limits	SR 951 (Collier Blvd) – 55 MPH	Championship Dr – 30 MPH
Adjacent Signalized Intersections	SR 951 at Manatee Rd – 1.04 mi north SR 951 at Fiddlers Creek Pkwy – 0.95 mi south	Championship Dr - None
SR 951 (Collier Blvd)	<u>Context / Functional Classification</u> – C3R Commercial Residential <u>Cross Section</u> – 4-lane divided with bike lanes and open drainage <u>Northbound Approach</u> – 2 thru lanes, 1 bike lane, and 1 right turn lane <u>Southbound Approach</u> – 2 thru lanes, 1 bike lane, and 1 left turn lane <u>Alignment</u> – Straight and level at the intersection <u>Sidewalks</u> – None <u>Utilities</u> – Overhead electric along the west side <u>Street Lighting</u> – None	
Championship Dr	<u>Context Classification</u> – Local roadway connecting SR 951 to residential developments <u>Cross Section</u> – 2-lane undivided with flush, unpaved shoulders <u>Westbound Approach</u> – 1 shared left turn/thru/right turn lane <u>Alignment</u> – Straight and level at the intersection <u>Sidewalks</u> – None <u>Utilities</u> – Overhead electric along the north side <u>Street Lighting</u> – One streetlight before stop bar	
Additional Features	None	



- | | | | | | |
|--|---------------------|--|---------------------|--|--------------------|
| | TRAFFIC SIGNAL POLE | | TRAFFIC SIGNAL HEAD | | UTILITY CABINET |
| | DITCH BOTTOM INLET | | MAN HOLE | | CONTROLLER CABINET |
| | MITERED END SECTION | | CURB INLET | | OVERHEAD LIGHT |
| | POWER POLE | | SIGN (SINGLE POST) | | HANDRAIL |
| | PEDESTRIAN SIGNAL | | MULTI POST SIGN | | FIRE HYDRANT |

BURGESS & NIPLE, INC.
 10006 N. DALE MABRY HWY, SUITE 201
 TAMPA, FL 33618

FIGURE 2
 CONDITION DIAGRAM

TRAFFIC VOLUMES

A 12-hour turning movement count (TMC) was conducted at the study intersection on Tuesday, February 18, 2021 for the hours of 7 AM – 7 PM. Due to the high volume of WB right turning vehicles, there was the potential that drivers might be performing NB to SB U-turns at the median opening 0.25 mile to the north rather than trying to make WB left turns from Championship Dr. An 8-hour TMC and an origin-destination (O-D) study using license plate readers were conducted at the median opening to measure this U-turn volume. The 8 hours chosen for the TMC and O-D study were 9 AM – 5 PM because those hours had the highest WB right turn volume during the original 12-hour TMC at Championship Dr.

The results of the O-D study showed 29 vehicles over the 8-hour study period made the downstream NB to SB U-turn at the median opening. The raw TMC summaries are shown in **Tables 2 & 3** and **Table 4** shows the peak 8-hour TMC at Championship Dr with the downstream U-turns added to the WB left turn volume. Detailed count information is included in the **Appendix**.

Table 2: TMC Summary – SR 951 at Championship Dr

TIME BEGIN/END	NORTHBOUND					SOUTHBOUND					TOTAL	WESTBOUND					TOTAL	TOTAL
	U	L	T	R	TOT	U	L	T	R	TOT	N/S	U	L	T	R	TOT	E/W	INT
7 - 8	0	0	702	2	704	0	89	1,639	0	1,728	2,432	0	14	0	178	192	192	2,624
8 - 9	0	0	936	20	956	5	184	1,631	0	1,820	2,776	0	16	0	272	288	288	3,064
9 - 10	0	0	1,145	29	1,174	4	191	1,432	0	1,627	2,801	0	15	0	335	350	350	3,151
10 - 11	1	0	1,450	25	1,476	3	214	1,328	0	1,545	3,021	0	13	0	382	395	395	3,416
11 - 12	0	0	1,411	26	1,437	2	263	1,473	0	1,738	3,175	0	13	0	357	370	370	3,545
12 - 1	0	0	1,401	28	1,429	0	298	1,439	0	1,737	3,166	0	9	0	356	365	365	3,531
1 - 2	0	0	1,441	40	1,481	3	274	1,398	0	1,675	3,156	0	8	0	318	326	326	3,482
2 - 3	0	0	1,560	26	1,586	7	286	1,505	0	1,798	3,384	0	11	0	319	330	330	3,714
3 - 4	0	0	1,810	32	1,842	1	243	1,462	0	1,706	3,548	0	8	0	299	307	307	3,855
4 - 5	0	0	1,758	43	1,801	1	221	1,496	0	1,718	3,519	0	9	0	281	290	290	3,809
5 - 6	0	0	1,624	32	1,656	3	215	1,207	0	1,425	3,081	0	19	0	244	263	263	3,344
6 - 7	0	0	1,101	29	1,130	1	222	904	0	1,127	2,257	0	20	0	197	217	217	2,474
TOTAL	1	0	16,339	332	16,672	30	2,700	16,914	0	19,644	36,316	0	155	0	3,538	3,693	3,693	40,009

Table 3: TMC Summary – SR 951 at Median Opening North of Championship Dr

TIME BEGIN/END	NORTHBOUND					SOUTHBOUND					TOTAL	EASTBOUND					TOTAL	TOTAL
	U	L	T	R	TOT	U	L	T	R	TOT	N/S	U	L	T	R	TOT	E/W	INT
9 - 10	7	2	1,203	-	1,212	1	-	1,307	0	1,308	2,520	0	0	-	1	1	1	2,521
10 - 11	7	0	1,377	-	1,384	0	-	1,318	0	1,318	2,702	0	0	-	0	0	0	2,702
11 - 12	5	0	1,413	-	1,418	0	-	1,296	0	1,296	2,714	0	0	-	0	0	0	2,714
12 - 1	6	0	1,441	-	1,447	0	-	1,261	0	1,261	2,708	0	0	-	0	0	0	2,708
1 - 2	11	3	1,406	-	1,420	0	-	1,357	0	1,357	2,777	0	1	-	2	3	3	2,780
2 - 3	8	2	1,553	-	1,563	0	-	1,320	0	1,320	2,883	0	0	-	0	0	0	2,883
3 - 4	7	1	1,663	-	1,671	0	-	1,437	1	1,438	3,109	0	7	-	1	8	8	3,117
4 - 5	6	0	1,828	-	1,834	0	-	1,255	0	1,255	3,089	0	0	-	1	1	1	3,090
TOTAL	57	8	11,884	-	11,949	1	0	10,551	1	10,553	22,502	0	8	-	5	13	13	22,515

Table 4: TMC Summary – SR 951 at Championship Dr with Median Opening U-Turns

TIME BEGIN/END	NORTHBOUND					SOUTHBOUND					TOTAL	WESTBOUND					TOTAL	TOTAL
	U	L	T	R	TOT	U	L	T	R	TOT	N/S	U*	L	U+L**	R	TOT	E/W	INT
7 - 8	0	0	702	2	704	0	89	1,639	0	1,728	2,432	-	14	14	178	192	192	2,624
8 - 9	0	0	936	20	956	5	184	1,631	0	1,820	2,776	-	16	16	272	288	288	3,064
9 - 10	0	0	1,145	29	1,174	4	191	1,432	0	1,627	2,801	3	15	18	335	353	353	3,154
10 - 11	1	0	1,450	25	1,476	3	214	1,328	0	1,545	3,021	4	13	17	382	399	399	3,420
11 - 12	0	0	1,411	26	1,437	2	263	1,473	0	1,738	3,175	2	13	15	357	372	372	3,547
12 - 1	0	0	1,401	28	1,429	0	298	1,439	0	1,737	3,166	3	9	12	356	368	368	3,534
1 - 2	0	0	1,441	40	1,481	3	274	1,398	0	1,675	3,156	5	8	13	318	331	331	3,487
2 - 3	0	0	1,560	26	1,586	7	286	1,505	0	1,798	3,384	7	11	18	319	337	337	3,721
3 - 4	0	0	1,810	32	1,842	1	243	1,462	0	1,706	3,548	3	8	11	299	310	310	3,858
4 - 5	0	0	1,758	43	1,801	1	221	1,496	0	1,718	3,519	2	9	11	281	292	292	3,811
5 - 6	0	0	1,624	32	1,656	3	215	1,207	0	1,425	3,081	-	19	19	244	263	263	3,344
6 - 7	0	0	1,101	29	1,130	1	222	904	0	1,127	2,257	-	20	20	197	217	217	2,474
TOTAL	1	0	16,339	332	16,672	30	2,700	16,914	0	19,644	36,316	29	155	184	3,538	3,722	3,722	40,038

* NB to SB U-turns at the northern median opening originating from Championship Dr

**Median opening U-turns combined with WB left turns from Championship Dr to SB SR 951

INTERSECTION DELAY

To measure the stop sign delay, an electronic count board manufactured by JAMAR Technologies, Inc. for collecting traffic data was used with the STOP Sign Delay template to collect the necessary data for stop sign delay and queue length estimates. The study was conducted February 18, 2021 for the westbound approach under STOP sign control during the side street midday and afternoon peak hours. Additional delay data is included in the Appendix and **Table 5** summarizes the results of these studies.

Table 5: Delay Study Summary

10:00 AM – 11:00 AM	Westbound
Volume (vehicles/hour)	392
Average Delay Per Vehicle (seconds)	40
Max Queue (vehicles)	13
Max Delay per Vehicle (seconds)	139
Total Delay (vehicle-seconds)	15735
Total Delay (vehicle-hours)	4.38

2:00 PM – 3:00 PM	Westbound
Volume (vehicles/hour)	328
Average Delay Per Vehicle (seconds)	28
Max Queue (vehicles)	8
Max Delay per Vehicle (seconds)	91
Total Delay (vehicle-seconds)	9265
Total Delay (vehicle-hours)	2.57

During the peak hours observed, the average delay experienced by WB traffic ranged from 28 to 40 seconds per vehicle and the maximum delay for a single vehicle was 139 seconds. As a reference, an average delay of 60 seconds per vehicle is the approximate delay to be expected if the intersection was signalized.

COLLISION DATA

Collision data was obtained from January 1, 2017 to December 31, 2019 from FDOT’s CAR database and the University of Florida’s Signal 4 Analytics for the study intersection. A total of 19 crashes were reported at this intersection during the 36-month study period. An overview of the Collision Statistics can be found on **Table 6** and additional details can be found in the Collision Summary on **Table 7** and in the Collision Diagram on **Figure 3**.

- There were no reported fatalities, and 6 crashes resulted in 8 injuries.
- One bicycle crash and zero pedestrian crashes were reported.
- 2 angle type crashes were reported
- Additional reported crashes include 13 rear end, 1 sideswipe, 1 off-road, and 1 fixed object

Table 6: Collision Statistics

Crash Type	2017	2018	2019	Total
Rear End	4	4	5	13
Angle	1	1		2
Sideswipe			1	1
Bicycle		1		1
Off Road		1		1
Fixed Object			1	1
TOTAL	5	7	7	19
Fatalities	0	0	0	0
Injuries	3 (5)	2 (2)	1 (1)	6 (8)
Day	3	7	7	17
Night	2	0	0	2
Wet Conditions	0	1	3	4
Dry Conditions	5	6	4	15

Table 7: Collision Summary

State of Florida Department of Transportation											Form 750-020-06	
COLLISION SUMMARY											TRAFFIC ENGINEERING 10/15	
General Information												
Section/Roadway ID:			XXXXXXXX				State Road:			SR 951		
Intersecting Route:			Championship Dr				Study Period:			January 1, 2017 to December 31, 2019		
Milepost			X.XX				Data by:			ML		
County			Collier				Date:			Saturday, September 18, 2021		
No.	Date	Day	Time	Severity		Property Damage	Crash Type	Day / Night	Wet / Dry	Contributing Cause		
				Fatal	Injury							
1	1/25/17	Wed	6:46 PM	0	1	\$10,000	Angle	Night	Dry	Failure to Yield to R/W		
2	2/17/17	Fri	10:13 AM	0	0	\$0	Rear End	Day	Dry	Following too Closely		
3	9/22/17	Fri	1:09 PM	0	2	\$7,000	Rear End	Day	Dry	Following too Closely		
4	11/7/17	Tue	4:50 PM	0	2	\$1,000	Rear End	Day	Dry	Careless Driving		
5	11/10/17	Fri	6:05 PM	0	0	\$2,000	Rear End	Night	Dry	Careless Driving		
6	2/6/18	Tue	11:05 AM	0	0	\$11,000	Rear End	Day	Dry	Following too Closely		
7	2/28/18	Wed	9:48 AM	0	1	\$850	Bicycle	Day	Dry	Improper Lane Change		
8	3/5/18	Mon	9:30 AM	0	0	\$700	Rear End	Day	Dry	Careless Driving		
9	8/31/18	Fri	4:45 PM	0	1	\$7,000	Rear End	Day	Wet	Following too Closely		
10	11/21/18	Wed	9:55 AM	0	0	\$5,000	Angle	Day	Dry	Failure to Yield to R/W		
11	11/27/18	Tue	1:45 PM	0	0	\$4,500	Rear End	Day	Dry	Careless Driving		
12	12/3/18	Mon	3:55 PM	0	0	\$1,000	Off Road	Day	Dry	Illegal U-turn		
13	3/12/19	Tue	11:05 AM	0	1	\$4,500	Fixed Object	Day	Dry	Careless Driving		
14	6/9/19	Sun	8:50 AM	0	0	\$2,500	Rear End	Day	Wet	Following too Closely		
15	7/16/19	Tue	2:42 PM	0	0	\$3,500	Rear End	Day	Wet	Following too Closely		
16	10/28/19	Mon	4:38 PM	0	0	\$0	Sideswipe	Day	Wet	Failure to Yield to R/W		
17	11/11/19	Mon	2:57 PM	0	0	\$2,500	Rear End	Day	Dry	Following too Closely		
18	11/27/19	Wed	3:49 PM	0	0	\$2,500	Rear End	Day	Dry	Following too Closely		
19	11/28/19	Thu	10:54 AM	0	0	\$0	Rear End	Day	Dry	Following too Closely		
TOTAL				0	8	\$65,550						
Total No.	Fatal	Injury	PDO	Angle	Bicycle	Fixed Object	Left Turn	Off Road	Pedestrian	Rear End	Right Turn	Sideswipe
19	0	8	11	2	1	1	0	1	0	13	0	1
Percent	0%	42%	58%	11%	5%	5%	0%	5%	0%	68%	0%	5%
Contrib. Cause	Day	Night	Pavement Conditions			Careless Driving	Avoiding Ped/Veh	Failure to Yield R/W	Following too Closely	Medical Emergency	Illegal U-turn	Improper Lane Change
			Wet	Dry	Unknown							
Total	17	2	4	15	0	5	0	3	9	0	1	1
Percent	89%	11%	21%	79%	0%	26%	0%	16%	47%	0%	5%	5%



- | | | | | | |
|---|---|---|------------------------|---|----------------------|
| ← | VEHICLE PATH | ↘ | OFF ROAD EVENT | ↶ | RIGHT TURN COLLISION |
| ⊕ | AT FAULT VEHICLE | ↙ | LEFT TURN COLLISION | ↵ | REAR-END COLLISION |
| ⊖ | CRASH AVOIDED, RESULTED IN OFF ROAD EVENT | ↗ | RIGHT ANGLE COLLISION | ↔ | HEAD-ON COLLISION |
| ○ | PERSONAL INJURY | ↻ | BICYCLE COLLISION | ↔ | SIDESWIPE COLLISION |
| ⊗ | FATALITY | ↻ | PEDESTRIAN COLLISION | ↻ | U-TURNING COLLISION |
| | | ↻ | FIXED OBJECT COLLISION | | |

BURGESS & NIPLE, INC.
 10006 N. DALE MABRY HWY, SUITE 201
 TAMPA, FL 33618

FIGURE 3
 COLLISION DIAGRAM
 1/1/2017 TO 12/31/2019

QUALITATIVE ASSESSMENT

The study intersection was observed by a registered professional engineer during the morning and afternoon peak periods to assess the existing operation/condition of the intersection, and to determine if a traffic signal is warranted.

Request: A request was submitted to determine if a traffic signal is warranted for the intersection of SR 951 (Collier Blvd) at Championship Dr.

Operations: Vehicle operations includes the operations and interactions of motor vehicles, pedestrians, and bicycles at the intersection. The following bullets provide a summary of the intersection traffic volumes and the observed field conditions at the intersection:

- SR 951 is the primary connection between US 41 to the north and Marco Island to the south. The study intersection also provides connectivity to SR 951 for some residential developments east of SR 951.
- NB and SB vehicles on SR 951 arrived in well defined platoons with gaps between platoons. Although the adjacent signalized intersections are approximately 1-mile away, the gaps likely stay well organized due to the low number of driveways or median openings along SR 951.
- Most WB left turning vehicles made one-stage turns due to the large number of bi-directional gaps between NB and SB traffic.
- The maximum SB left turn queue observed was 10 vehicles during the PM peak hour around 3:15 PM. All vehicles fit within the SB left turn lane and no queue spillover was observed.
- The WB stop bar is located roughly 50-ft east of the NB travel lane, requiring WB vehicles to pull in front of the stop bar prior to entering SR 951 to gain sight distance and to reduce their turning distance. Additionally, adjacent to the NB thru lane there is a NB striped bicycle key hole, a 6" white guideline, and approximately 17-ft of unstriped shoulder pavement. Some WB right turning drivers used the unstriped shoulder pavement as an acceleration lane with no safety issues observed.



Looking north along SR 951 at a WB right turn from the SE quadrant

-
- WB traffic on Championship Dr queued to a maximum of 13 vehicles during the NB/SB green phase at the SR 951 adjacent signals due to the lack of gaps. The WB queue generally fully cleared during the adjacent signal side street green phase, although some vehicles were observed waiting for a second side street green phase to enter SR 951.

Safety: Vehicle, pedestrian, and bicycle safety at the intersection is assessed through review of crash reports, identification of significant crash trends and contributing factors and their correlation to field conditions. Following are the observations relating to the safety of the intersection:

- WB right turning vehicles generally performed rolling stops when SR 951 traffic was stopped at the adjacent signals. Although no safety concerns were observed, this could be related to the 8 WB rear end crashes reported over the past 3 years. All 8 of the crash reports mentioned that the at-fault driver thought the vehicle in front was proceeding into the intersection but instead it stopped.
- Of the 13 rear end crashes reported, 8 involved WB right turning vehicles.

Overall Physical Conditions: In addition to observing operational and safety conditions, correctible physical conditions are also identified during the field review. The following observations were made during the field review:

- The pavement, signs, and pavement markings appear to be in good condition.

SIGNAL WARRANT ANALYSIS

The signal warrant analysis was done in accordance with the procedures and guidelines outlined in the latest versions of the Manual on Uniform Traffic Control Devices (MUTCD 2009) and the Manual on Uniform Traffic Studies (MUTS).

For the Signal Warrant Analysis, SR 951 (Collier Blvd) is considered the major street and Championship Dr is considered the minor street for all the peak hours. The minor street approach has one shared lane. The detailed signal warrant sheets from the MUTS can be found in Appendix D and **Table 8** summarizes the results of the warrant analysis. The following additional considerations were included in the analysis:

- Due to the large number of WB right turn volume from Championship Dr and the delay experienced entering SR 951, 50% of the right turn volume was included in the analysis.
- The 29 NB to SB U-turns at the northern median opening that originated from Championship Dr were added to the Championship Dr WB left turn volume. Then 50% of the WB right turn volume was added and the highest 8-hours of this combined volume was used in the analysis.
- Based on the posted speed limit of 55 mph on SR 951 (Collier Blvd) and the single lane on the minor street, the 70% volume and 1-lane minor street criteria were applied to the analysis.
- Only the types of reported crashes susceptible to correction by a traffic control signal (angle) within the 3-year study period were used in the analysis.

Table 8: Summary of Signal Warrant Analysis

Warrant		Applicable	Satisfied	Comments
1A	Minimum Vehicular Volume	Yes	Yes	The traffic volumes meet the requirements of this warrant.
1B	Interruption of Continuous Traffic	No	N/A	The traffic volumes meet the requirements of this warrant, but it is not applicable since Warrant 1A is satisfied.
2	Four Hour Vehicular Volume	Yes	Yes	The traffic volumes meet the requirements of this warrant.
3	Peak Hour	No	No	This warrant is not applicable. It is intended to be <i>applied only in unusual cases, such as office complexes, manufacturing plants, or high-occupancy vehicle facilities that attract or discharge large numbers of vehicles over a short time.</i>
4	Pedestrian Volume	Yes	No	The pedestrian volumes do not meet the requirement of this warrant.
5	School Crossing	No	No	This warrant is not applicable.
6	Coordinated Signal System	Yes	No	The conditions do not meet the requirements of this warrant.
7	Crash Experience	Yes	No	2 correctable (Angle) crashes were reported over the 36-month study period, which does not meet the 5-crashes in 12 months criteria.
8	Roadway Network	No	No	This warrant is not applicable.
9	Grade Crossing	No	No	This warrant is not applicable.

CONCLUSION

Based on the results of the Signal Warrant Analysis, field observations, and engineering judgment, the following conclusions were developed:

- This intersection meets Warrant 1 (8-hour volume) and Warrant 2 (4-hour volume) as listed in the Manual on Uniform Traffic Control Devices (MUTCD 2009).

APPENDIX A

Field Review Photos

Northbound Approach Photographs



Looking north at the intersection along SR 951



Looking south from the intersection along SR 951

Southbound Approach Photographs



Looking south at the intersection along SR 951



Looking north from the intersection along SR 951

Westbound Approach Photographs



Looking west at the intersection from Championship Drive



Looking east from the intersection towards Championship Drive

APPENDIX B

Detailed Count Data

**FLORIDA DEPARTMENT OF TRANSPORTATION
SUMMARY OF VEHICLE MOVEMENTS**

SECTION	03030	STATE ROUTE SR 951	COUNTY Collier
MILEPOST	7.578	INTERSECTING ROUTE Championship Dr & NB to SB U-turns	CITY Naples
OBSERVER	BURGESS & NIPLE	DATE 2/18/2021	
WEATHER	Clear	ROAD CONDITION Dry	
REMARKS	FORM COMPLETED BY DM		

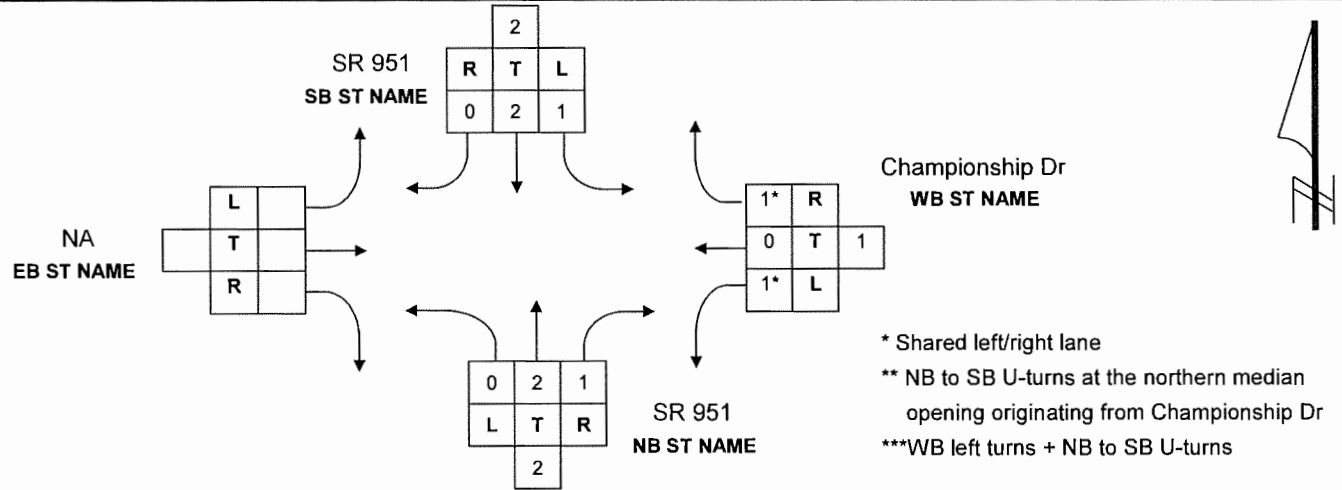

TIME BEGIN/END	NORTHBOUND					SOUTHBOUND					TOTAL	WESTBOUND					EASTBOUND				TOTAL	TOTAL
	U	L	T	R	TOT	U	L	T	R	TOT	N/S	U**	L	U+L***	R	TOT	L	T	R	TOT	E/W	INT
7 - 8	0	0	702	2	704	0	89	1,639	0	1,728	2,432	-	14	14	178	192	0	0	0	0	192	2,624
8 - 9	0	0	936	20	956	5	184	1,631	0	1,820	2,776	-	16	16	272	288	0	0	0	0	288	3,064
9 - 10	0	0	1,145	29	1,174	4	191	1,432	0	1,627	2,801	3	15	18	335	353	0	0	0	0	353	3,154
10 - 11	1	0	1,450	25	1,476	3	214	1,328	0	1,545	3,021	4	13	17	382	399	0	0	0	0	399	3,420
11 - 12	0	0	1,411	26	1,437	2	263	1,473	0	1,738	3,175	2	13	15	357	372	0	0	0	0	372	3,547
12 - 1	0	0	1,401	28	1,429	0	298	1,439	0	1,737	3,166	3	9	12	356	368	0	0	0	0	368	3,534
1 - 2	0	0	1,441	40	1,481	3	274	1,398	0	1,675	3,156	5	8	13	318	331	0	0	0	0	331	3,487
2 - 3	0	0	1,560	26	1,586	7	286	1,505	0	1,798	3,384	7	11	18	319	337	0	0	0	0	337	3,721
3 - 4	0	0	1,810	32	1,842	1	243	1,462	0	1,706	3,548	3	8	11	299	310	0	0	0	0	310	3,858
4 - 5	0	0	1,758	43	1,801	1	221	1,496	0	1,718	3,519	2	9	11	281	292	0	0	0	0	292	3,811
5 - 6	0	0	1,624	32	1,656	3	215	1,207	0	1,425	3,081	-	19	19	244	263	0	0	0	0	263	3,344
6 - 7	0	0	1,101	29	1,130	1	222	904	0	1,127	2,257	-	20	20	197	217	0	0	0	0	217	2,474
TOTAL	1	0	16,339	332	16,672					19,644	36,316	29	155	184	3,538	3,722	0	0	0	0	3,722	40,038
Percentage	0%	0%	98%	2%		0%	0%	0%	0%			-	4%	-	95%		0%	0%	0%			
Maximum	1	0	1810	43		7	298	1639	0			7	20	20	382		0	0	0			
Minimum	0	0	702	2		0	89	904	0			2	8	11	178		0	0	0			
Truck Percentage	100%	0.0%	4.4%	4.8%	4.4%	16.7%	5.3%	1.0%	4.1%	3.7%	-	0.0%	0.0%	0.0%	0.0%	0.0%	5.2%	0.0%	3.3%	3.4%	-	4.0%

**FLORIDA DEPARTMENT OF TRANSPORTATION
SUMMARY OF VEHICLE MOVEMENTS**

SECTION 03030 STATE ROUTE SR 951 COUNTY Collier
 MILEPOST 7.578 INTERSECTING ROUTE Championship Dr CITY Naples
 OBSERVER BURGESS & NIPLE DATE 2/18/2021
 WEATHER Clear ROAD CONDITION Dry

FORM COMPLETED BY DM

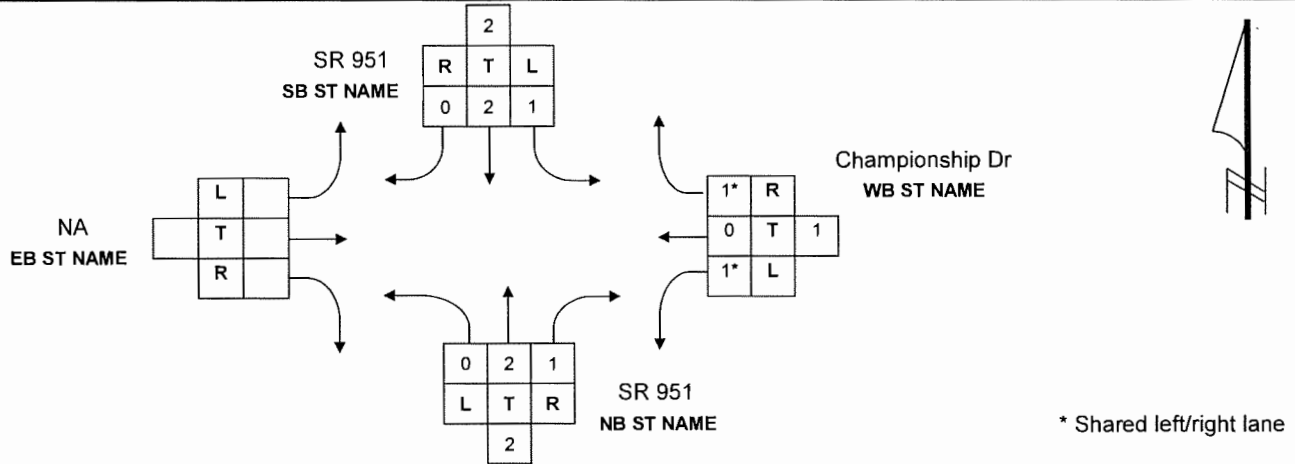

TIME BEGIN/END	NORTHBOUND					SOUTHBOUND					TOTAL N/S	EASTBOUND					WESTBOUND					TOTAL E/W	TOTAL INT	
	U	L	T	R	TOT	U	L	T	R	TOT		U	L	T	R	TOT	U	L	T	R	TOT			
7 - 8	0	0	702	2	704	0	89	1,639	0	1,728	2,432	0	0	0	0	0	0	14	0	178	192	192	2,624	
8 - 9	0	0	936	20	956	5	184	1,631	0	1,820	2,776	0	0	0	0	0	0	16	0	272	288	288	3,064	
9 - 10	0	0	1,145	29	1,174	4	191	1,432	0	1,627	2,801	0	0	0	0	0	0	15	0	335	350	350	3,151	
10 - 11	1	0	1,450	25	1,476	3	214	1,328	0	1,545	3,021	0	0	0	0	0	0	13	0	382	395	395	3,416	
11 - 12	0	0	1,411	26	1,437	2	263	1,473	0	1,738	3,175	0	0	0	0	0	0	13	0	357	370	370	3,545	
12 - 1	0	0	1,401	28	1,429	0	298	1,439	0	1,737	3,166	0	0	0	0	0	0	9	0	356	365	365	3,531	
1 - 2	0	0	1,441	40	1,481	3	274	1,398	0	1,675	3,156	0	0	0	0	0	0	8	0	318	326	326	3,482	
2 - 3	0	0	1,560	26	1,586	7	286	1,505	0	1,798	3,384	0	0	0	0	0	0	11	0	319	330	330	3,714	
3 - 4	0	0	1,810	32	1,842	1	243	1,462	0	1,706	3,548	0	0	0	0	0	0	8	0	299	307	307	3,855	
4 - 5	0	0	1,758	43	1,801	1	221	1,496	0	1,718	3,519	0	0	0	0	0	0	9	0	281	290	290	3,809	
5 - 6	0	0	1,624	32	1,656	3	215	1,207	0	1,425	3,081	0	0	0	0	0	0	19	0	244	263	263	3,344	
6 - 7	0	0	1,101	29	1,130	1	222	904	0	1,127	2,257	0	0	0	0	0	0	20	0	197	217	217	2,474	
TOTAL	1	0	16,339	332	16,672	30	2,700	16,914	0	19,644	36,316	0	0	0	0	0	0	155	0	3,538	3,693	3,693	40,009	
Percentage	0%	0%	98%	2%		0%	14%	86%	0%			0%	0%	0%	0%			0%	4%	0%	96%			
Maximum	1	0	1810	43		7	298	1639	0			0	0	0	0			0	20	0	382			
Minimum	0	0	702	2		0	89	904	0			0	0	0	0			0	8	0	178			
Truck Percentage	100%	0.0%	4.4%	4.8%	4.4%	16.7%	5.3%	1.0%	4.1%	3.7%	-	0.0%	0.0%	0.0%	0.0%	0.0%	0.0%	0.0%	5.2%	0.0%	3.3%	3.4%	-	4.0%

BURGESS & NIPLE

SR 951 at Championship Dr
 Section: 03030 MP: 7.578
 Weather: Clear
 County: Collier

10006 N. Dale Mabry Suite 201
 Tampa, Florida, United States 33618
 (813) 962-8689

Count Name: 102_SR 951 at Championship Dr -
 TMC
 Start Date: 02/18/2021
 Page No: 1

Vehicles & Heavy Vehicles

Start Time	SR 951 Northbound				SR 951 Southbound				Championship Dr Westbound				Int. Total
	U-Turn	TH	RT	App. Total	U-Turn	LT	TH	App. Total	U-Turn	LT	RT	App. Total	
7:00 AM	0	145	0	145	0	13	310	323	0	1	40	41	509
7:15 AM	0	180	1	181	0	15	382	397	0	7	45	52	630
7:30 AM	0	190	0	190	0	24	497	521	0	4	46	50	761
7:45 AM	0	187	1	188	0	37	450	487	0	2	47	49	724
Hourly Total	0	702	2	704	0	89	1639	1728	0	14	178	192	2624
8:00 AM	0	202	3	205	1	45	406	452	0	1	53	54	711
8:15 AM	0	213	7	220	2	39	391	432	0	6	61	67	719
8:30 AM	0	265	3	268	2	44	445	491	0	5	67	72	831
8:45 AM	0	256	7	263	0	56	389	445	0	4	91	95	803
Hourly Total	0	936	20	956	5	184	1631	1820	0	16	272	288	3064
9:00 AM	0	254	6	260	0	40	380	420	0	2	75	77	757
9:15 AM	0	256	6	262	2	53	307	362	0	5	71	76	700
9:30 AM	0	354	7	361	1	36	360	397	0	5	98	103	861
9:45 AM	0	281	10	291	1	62	385	448	0	3	91	94	833
Hourly Total	0	1145	29	1174	4	191	1432	1627	0	15	335	350	3151
10:00 AM	1	332	6	339	1	46	319	366	0	4	98	102	807
10:15 AM	0	437	7	444	1	44	333	378	0	3	95	98	920
10:30 AM	0	354	5	359	1	63	332	396	0	1	105	106	861
10:45 AM	0	327	7	334	0	61	344	405	0	5	84	89	828
Hourly Total	1	1450	25	1476	3	214	1328	1545	0	13	382	395	3416
11:00 AM	0	362	7	369	0	67	314	381	0	3	90	93	843
11:15 AM	0	347	6	353	2	61	367	430	0	3	95	98	881
11:30 AM	0	341	8	349	0	67	405	472	0	5	89	94	915
11:45 AM	0	361	5	366	0	68	387	455	0	2	83	85	906
Hourly Total	0	1411	26	1437	2	263	1473	1738	0	13	357	370	3545
12:00 PM	0	319	9	328	0	72	348	420	0	1	99	100	848
12:15 PM	0	395	9	404	0	67	343	410	0	3	78	81	695
12:30 PM	0	372	6	378	0	87	407	494	0	4	91	95	967
12:45 PM	0	315	4	319	0	72	341	413	0	1	88	89	821
Hourly Total	0	1401	28	1429	0	298	1439	1737	0	9	356	365	3531
1:00 PM	0	371	7	378	0	75	346	421	0	1	76	77	876
1:15 PM	0	370	10	380	0	60	352	412	0	5	76	81	873
1:30 PM	0	365	16	381	3	58	324	385	0	2	80	82	848
1:45 PM	0	335	7	342	0	81	376	457	0	0	86	86	885
Hourly Total	0	1441	40	1481	3	274	1398	1675	0	8	318	326	3482
2:00 PM	0	383	10	393	1	64	346	411	0	4	97	101	905
2:15 PM	0	411	4	415	1	69	383	453	0	2	87	89	957
2:30 PM	0	360	6	366	2	71	417	490	0	4	61	65	921

2:45 PM	0	406	6	0	412	3	82	359	0	444	0	1	74	0	75	931
Hourly Total	0	1560	26	0	1586	7	286	1505	0	1798	0	11	319	0	330	3714
3:00 PM	0	416	9	0	425	0	65	330	0	395	0	1	83	0	84	904
3:15 PM	0	448	6	0	454	0	58	350	0	408	0	2	73	0	75	937
3:30 PM	0	476	12	0	488	0	61	412	0	473	0	4	74	0	78	1039
3:45 PM	0	470	5	0	475	1	59	370	0	430	0	1	69	0	70	975
Hourly Total	0	1810	32	0	1842	1	243	1462	0	1706	0	8	299	0	307	3855
4:00 PM	0	456	9	0	465	1	56	348	0	405	0	2	78	0	80	950
4:15 PM	0	464	15	0	479	0	46	401	0	447	0	1	60	0	61	987
4:30 PM	0	437	7	0	444	0	63	376	0	439	0	2	79	0	81	964
4:45 PM	0	401	12	0	413	0	56	371	0	427	0	4	64	0	68	908
Hourly Total	0	1758	43	0	1801	1	221	1496	0	1718	0	9	281	0	290	3809
5:00 PM	0	448	12	0	460	0	67	361	0	428	0	4	75	0	79	967
5:15 PM	0	429	7	0	436	1	54	317	0	372	0	7	59	0	66	874
5:30 PM	0	403	8	0	411	0	47	253	0	300	0	3	59	0	62	773
5:45 PM	0	344	5	0	349	2	47	276	0	325	0	5	51	0	56	730
Hourly Total	0	1624	32	0	1656	3	215	1207	0	1425	0	19	244	0	263	3344
6:00 PM	0	322	10	0	332	0	50	249	0	299	0	4	63	0	67	698
6:15 PM	0	283	6	0	289	0	56	206	0	262	0	10	53	0	63	614
6:30 PM	0	265	5	0	270	0	57	243	0	300	0	2	48	0	50	620
6:45 PM	0	231	8	0	239	1	59	206	0	266	0	4	33	0	37	542
Hourly Total	0	1101	29	0	1130	1	222	904	0	1127	0	20	197	0	217	2474
Grand Total	1	16339	332	0	16672	30	2700	16914	0	19644	0	155	3538	0	3693	40009
Approach %	0.0	98.0	2.0	-	-	0.2	13.7	86.1	-	-	0.0	4.1	95.8	-	-	-
Total %	0.0	40.8	0.8	-	41.7	0.1	6.7	42.3	-	49.1	0.0	0.4	8.8	-	9.2	-
Vehicles	0	15597	316	-	15913	25	2673	16200	-	18898	0	147	3418	-	3565	38376
% Vehicles	0.0	95.5	95.2	-	95.4	83.3	99.0	95.8	-	96.2	0.0	94.8	96.6	-	96.5	95.9
Heavy Vehicles	1	721	16	-	738	5	27	694	-	726	0	8	117	-	125	1589
% Heavy Vehicles	100.0	4.4	4.8	-	4.4	16.7	1.0	4.1	-	3.7	0.0	5.2	3.3	-	3.4	4.0
Bicycles on Road	0	21	0	-	21	0	0	20	-	20	0	0	3	-	3	44
% Bicycles on Road	0.0	0.1	0.0	-	0.1	0.0	0.0	0.1	-	0.1	0.0	0.0	0.1	-	0.1	0.1

BURGESS & NIPLE

SR 951 at Championship Dr
 Section: 03030 MP: 7.578
 Weather: Clear
 County: Collier

10006 N. Dale Mabry Suite 201
 Tampa, Florida, United States 33618
 (813) 962-8689

Count Name: 102_SR 951 at Championship Dr -
 TMC
 Start Date: 02/18/2021
 Page No: 1

Heavy Vehicles

Start Time	SR 951 Northbound				SR 951 Southbound				Championship Dr Westbound				Int. Total
	U-Turn	TH	RT	App. Total	U-Turn	LT	TH	App. Total	U-Turn	LT	RT	App. Total	
7:00 AM	0	6	0	6	0	0	30	30	0	0	0	0	36
7:15 AM	0	6	1	7	0	1	32	33	0	0	1	1	41
7:30 AM	0	8	0	8	0	1	28	29	0	0	1	1	38
7:45 AM	0	11	1	12	0	1	25	26	0	0	2	2	40
Hourly Total	0	31	2	33	0	3	115	118	0	0	4	4	155
8:00 AM	0	14	0	14	1	5	32	38	0	0	1	1	53
8:15 AM	0	16	1	17	1	1	36	38	0	0	3	3	58
8:30 AM	0	15	0	15	0	1	21	22	0	0	1	1	38
8:45 AM	0	12	0	12	0	1	24	25	0	0	4	4	41
Hourly Total	0	57	1	58	2	8	113	123	0	0	9	9	190
9:00 AM	0	12	0	12	0	1	30	31	0	0	2	2	45
9:15 AM	0	10	0	10	0	1	18	19	0	1	0	1	30
9:30 AM	0	15	0	15	1	0	27	28	0	1	1	2	45
9:45 AM	0	12	0	12	1	0	27	28	0	1	2	3	43
Hourly Total	0	49	0	49	2	2	102	106	0	3	5	8	163
10:00 AM	1	15	0	16	1	0	22	23	0	0	2	2	41
10:15 AM	0	20	0	20	0	1	21	22	0	0	4	4	46
10:30 AM	0	17	0	17	0	0	19	19	0	0	3	3	39
10:45 AM	0	16	1	17	0	0	19	19	0	1	4	5	41
Hourly Total	1	68	1	70	1	1	81	83	0	1	13	14	167
11:00 AM	0	11	0	11	0	0	20	20	0	0	2	2	33
11:15 AM	0	19	0	19	0	2	13	15	0	0	4	4	38
11:30 AM	0	12	1	13	0	0	12	12	0	0	3	3	28
11:45 AM	0	16	0	16	0	2	24	26	0	0	6	6	48
Hourly Total	0	58	1	59	0	4	69	73	0	0	15	15	147
12:00 PM	0	19	1	20	0	0	16	16	0	0	3	3	39
12:15 PM	0	18	0	18	0	0	12	12	0	0	2	2	32
12:30 PM	0	17	1	18	0	1	9	10	0	2	4	6	34
12:45 PM	0	12	0	12	0	2	14	16	0	0	3	3	31
Hourly Total	0	66	2	68	0	3	51	54	0	2	12	14	136
1:00 PM	0	17	1	18	0	1	7	8	0	0	2	2	28
1:15 PM	0	16	1	17	0	0	14	14	0	0	0	0	31
1:30 PM	0	27	2	29	0	0	10	10	0	0	1	1	40
1:45 PM	0	22	0	22	0	0	15	15	0	0	2	2	39
Hourly Total	0	82	4	86	0	1	46	47	0	0	5	5	138
2:00 PM	0	20	0	20	0	0	10	10	0	0	3	3	33
2:15 PM	0	21	1	22	0	1	16	17	0	0	5	5	44
2:30 PM	0	15	0	15	0	0	15	15	0	0	3	3	33

2:45 PM	0	33	1	0	34	0	0	8	0	8	0	0	6	0	6	48
Hourly Total	0	89	2	0	91	0	1	49	0	50	0	0	17	0	17	158
3:00 PM	0	23	0	0	23	0	0	7	0	7	0	0	3	0	3	33
3:15 PM	0	15	1	0	16	0	0	6	0	6	0	0	4	0	4	26
3:30 PM	0	21	0	0	21	0	1	4	0	5	0	0	1	0	1	27
3:45 PM	0	20	1	0	21	0	0	6	0	6	0	1	9	0	10	37
Hourly Total	0	79	2	0	81	0	1	23	0	24	0	1	17	0	18	123
4:00 PM	0	28	0	0	28	0	0	6	0	6	0	0	6	0	6	40
4:15 PM	0	13	0	0	13	0	0	7	0	7	0	0	0	0	0	20
4:30 PM	0	20	0	0	20	0	0	6	0	6	0	0	3	0	3	29
4:45 PM	0	8	0	0	8	0	0	6	0	6	0	1	1	0	2	16
Hourly Total	0	69	0	0	69	0	0	25	0	25	0	1	10	0	11	105
5:00 PM	0	11	1	0	12	0	1	6	0	7	0	0	0	0	0	19
5:15 PM	0	14	0	0	14	0	0	5	0	5	0	0	3	0	3	22
5:30 PM	0	14	0	0	14	0	0	2	0	2	0	0	2	0	2	18
5:45 PM	0	11	0	0	11	0	0	2	0	2	0	0	4	0	4	17
Hourly Total	0	50	1	0	51	0	1	15	0	16	0	0	9	0	9	76
6:00 PM	0	8	0	0	8	0	1	2	0	3	0	0	0	0	0	11
6:15 PM	0	5	0	0	5	0	0	2	0	2	0	0	1	0	1	8
6:30 PM	0	4	0	0	4	0	1	1	0	2	0	0	0	0	0	6
6:45 PM	0	6	0	0	6	0	0	0	0	0	0	0	0	0	0	6
Hourly Total	0	23	0	0	23	0	2	5	0	7	0	0	1	0	1	31
Grand Total	1	721	16	0	738	5	27	694	0	726	0	8	117	0	125	1589
Approach %	0.1	97.7	2.2	-	-	0.7	3.7	95.6	-	-	0.0	6.4	93.6	-	-	-
Total %	0.1	45.4	1.0	-	46.4	0.3	1.7	43.7	-	45.7	0.0	0.5	7.4	-	7.9	-
Heavy Vehicles	1	721	16	-	738	5	27	694	-	726	0	8	117	-	125	1589
% Heavy Vehicles	100.0	100.0	100.0	-	100.0	100.0	100.0	100.0	-	100.0	-	100.0	100.0	-	100.0	100.0

SR 951 at Championship Dr
 Section: 03030 MP: 7.578
 Weather: Clear
 County: Collier

Pedestrian / Bicycle Count Field Data Sheet

File Name: 102_Ped-Bike
 Start Date: 2/18/2021
 Start Time: 7:00 AM
 End Time: 7:00 PM

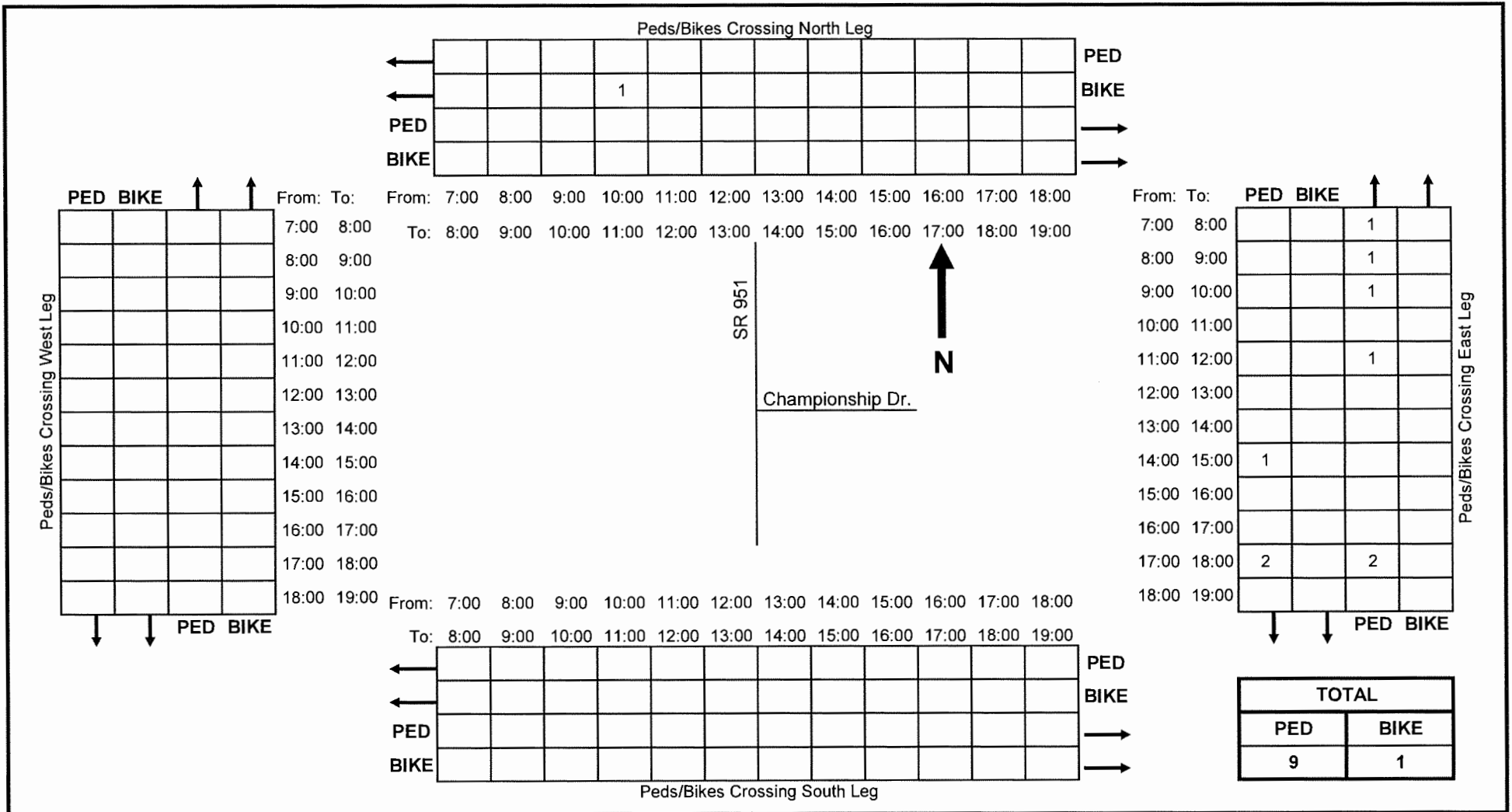

**FLORIDA DEPARTMENT OF TRANSPORTATION
SUMMARY OF VEHICLE MOVEMENTS**

SECTION	03030	STATE ROUTE SR 951	COUNTY Collier
MILEPOST	7.828	INTERSECTING ROUTE Median Opening	CITY Naples
OBSERVER	BURGESS & NIPLÉ	DATE 5/5/2021	
WEATHER	Clear	ROAD CONDITION Dry	
REMARKS	_____		

FORM COMPLETED BY DM

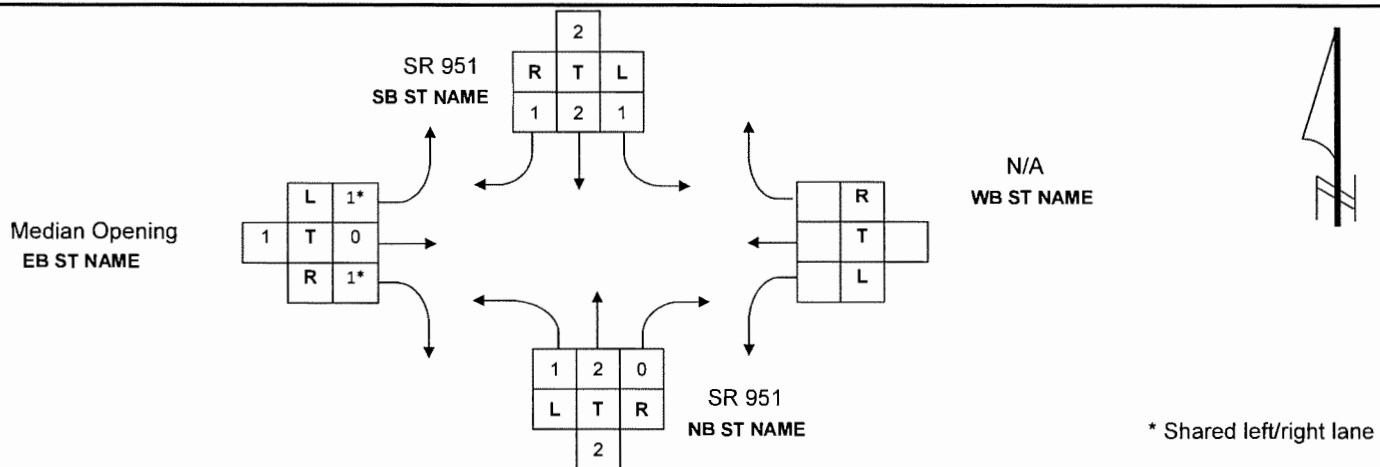

TIME BEGIN/END	NORTHBOUND					SOUTHBOUND					TOTAL N/S	EASTBOUND					WESTBOUND					TOTAL E/W	TOTAL INT
	U	L	T	R	TOT	U	L	T	R	TOT		U	L	T	R	TOT	U	L	T	R	TOT		
9 - 10	7	2	1,203	-	1,212	1	-	1,307	0	1,308	2,520	0	0	-	1	1	-	-	-	-	-	1	2,521
10 - 11	7	0	1,377	-	1,384	0	-	1,318	0	1,318	2,702	0	0	-	0	0	-	-	-	-	-	0	2,702
11 - 12	5	0	1,413	-	1,418	0	-	1,296	0	1,296	2,714	0	0	-	0	0	-	-	-	-	-	0	2,714
12 - 1	6	0	1,441	-	1,447	0	-	1,261	0	1,261	2,708	0	0	-	0	0	-	-	-	-	-	0	2,708
1 - 2	11	3	1,406	-	1,420	0	-	1,357	0	1,357	2,777	0	1	-	2	3	-	-	-	-	-	3	2,780
2 - 3	8	2	1,553	-	1,563	0	-	1,320	0	1,320	2,883	0	0	-	0	0	-	-	-	-	-	0	2,883
3 - 4	7	1	1,663	-	1,671	0	-	1,437	1	1,438	3,109	0	7	-	1	8	-	-	-	-	-	8	3,117
4 - 5	6	0	1,828	-	1,834	0	-	1,255	0	1,255	3,089	0	0	-	1	1	-	-	-	-	-	1	3,090
TOTAL	57	8	11,884	-	11,949	1	-	10,551	1	10,553	22,502	0	8	-	5	13	-	-	-	-	-	13	22,515
Percentage	0%	0%	99%	-		0%	-	100%	0%			0%	62%	-	38%		-	-	-	-	-		
Maximum	11	3	1828	-		1	-	1437	1			0	7	-	2		-	-	-	-	-		
Minimum	5	0	1203	-		0	-	1255	0			0	0	-	0		-	-	-	-	-		
Truck Percentage	5.3%	62.5%	6.0%	-	6.1%	0.0%	-	4.2%	0.0%	4.2%	-	0.0%	25.0%	-	0.0%	15.4%	-	-	-	-	-	-	5.2%

Intersection Turning Movement Count

SR 951/Collier Blvd @ Median Break
n/o Championship Dr

File Name : 21076-1
Site Code : 21076-1
Start Date : 5/5/2021
Page No : 1

Groups Printed- Automobiles - Trucks - Buses

Start Time	SR 951/Collier Blvd Southbound				SR 951/Collier Blvd Northbound				Belle Meade Service Center Eastbound				Int. Total
	Thru	Right	Utorns	App. Total	Left	Thru	Utorns	App. Total	Left	Right	Utrns	App. Total	
09:00	304	0	0	304	1	284	4	289	0	0	0	0	593
09:15	316	0	0	316	0	314	0	314	0	0	0	0	630
09:30	345	0	0	345	1	292	2	295	0	0	0	0	640
09:45	342	0	1	343	0	313	1	314	0	1	0	1	658
Total	1307	0	1	1308	2	1203	7	1212	0	1	0	1	2521
10:00	348	0	0	348	0	337	0	337	0	0	0	0	685
10:15	296	0	0	296	0	351	2	353	0	0	0	0	649
10:30	330	0	0	330	0	350	4	354	0	0	0	0	684
10:45	344	0	0	344	0	339	1	340	0	0	0	0	684
Total	1318	0	0	1318	0	1377	7	1384	0	0	0	0	2702
11:00	306	0	0	306	0	372	2	374	0	0	0	0	680
11:15	309	0	0	309	0	350	0	350	0	0	0	0	659
11:30	314	0	0	314	0	334	2	336	0	0	0	0	650
11:45	367	0	0	367	0	357	1	358	0	0	0	0	725
Total	1296	0	0	1296	0	1413	5	1418	0	0	0	0	2714
12:00	310	0	0	310	0	340	3	343	0	0	0	0	653
12:15	307	0	0	307	0	381	0	381	0	0	0	0	688
12:30	334	0	0	334	0	349	2	351	0	0	0	0	685
12:45	310	0	0	310	0	371	1	372	0	0	0	0	682
Total	1261	0	0	1261	0	1441	6	1447	0	0	0	0	2708
13:00	350	0	0	350	0	375	4	379	0	0	0	0	729
13:15	293	0	0	293	1	353	3	357	0	0	0	0	650
13:30	361	0	0	361	2	379	2	383	0	1	0	1	745
13:45	353	0	0	353	0	299	2	301	1	1	0	2	656
Total	1357	0	0	1357	3	1406	11	1420	1	2	0	3	2780
14:00	319	0	0	319	2	363	3	368	0	0	0	0	687
14:15	349	0	0	349	0	437	2	439	0	0	0	0	788
14:30	336	0	0	336	0	409	2	411	0	0	0	0	747
14:45	316	0	0	316	0	344	1	345	0	0	0	0	661
Total	1320	0	0	1320	2	1553	8	1563	0	0	0	0	2883
15:00	331	0	0	331	0	398	1	399	0	0	0	0	730
15:15	366	0	0	366	1	443	0	444	2	0	0	2	812
15:30	383	0	0	383	0	401	3	404	5	0	0	5	792
15:45	357	1	0	358	0	421	3	424	0	1	0	1	783
Total	1437	1	0	1438	1	1663	7	1671	7	1	0	8	3117
16:00	328	0	0	328	0	476	0	476	0	0	0	0	804
16:15	301	0	0	301	0	468	3	471	0	1	0	1	773
16:30	327	0	0	327	0	439	2	441	0	0	0	0	768
16:45	299	0	0	299	0	445	1	446	0	0	0	0	745
Total	1255	0	0	1255	0	1828	6	1834	0	1	0	1	3090
Grand Total	10551	1	1	10553	8	11884	57	11949	8	5	0	13	22515
Apprch %	100	0	0		0.1	99.5	0.5		61.5	38.5	0		
Total %	46.9	0	0	46.9	0	52.8	0.3	53.1	0	0	0	0.1	
Automobiles	10109	1	1	10111	3	11167	54	11224	6	5	0	11	21346
% Automobiles	95.8	100	100	95.8	37.5	94	94.7	93.9	75	100	0	84.6	94.8
Trucks	414	0	0	414	5	693	2	700	2	0	0	2	1116
% Trucks	3.9	0	0	3.9	62.5	5.8	3.5	5.9	25	0	0	15.4	5
Buses	28	0	0	28	0	24	1	25	0	0	0	0	53
% Buses	0.3	0	0	0.3	0	0.2	1.8	0.2	0	0	0	0	0.2

Intersection Turning Movement Count

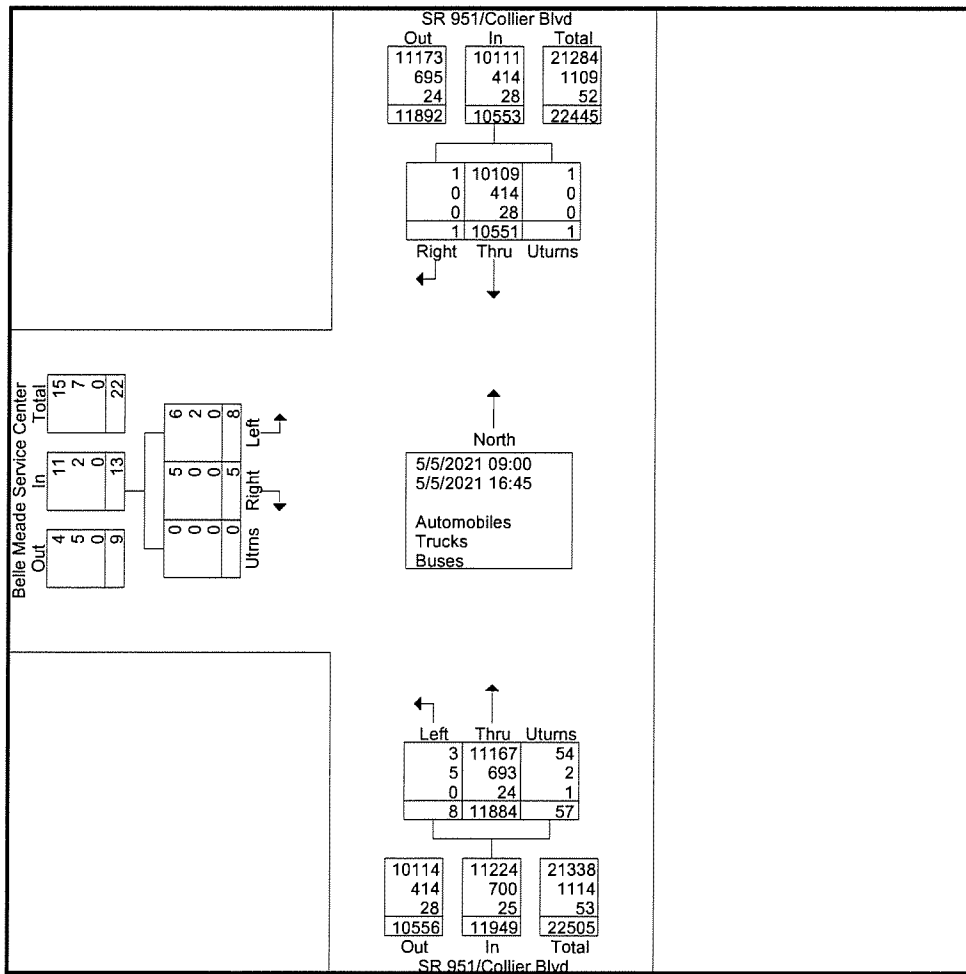

Intersection Turning Movement Count

SR 951/Collier Blvd @ Median Break
n/o Championship Dr

File Name : 21076-1
Site Code : 21076-1
Start Date : 5/5/2021
Page No : 3

Start Time	SR 951/Collier Blvd Southbound				SR 951/Collier Blvd Northbound				Belle Meade Service Center Eastbound				Int. Total
	Thru	Right	Utrns	App. Total	Left	Thru	Utrns	App. Total	Left	Right	Utrns	App. Total	
Peak Hour Analysis From 09:00 to 13:00 - Peak 1 of 1													
Peak Hour for Entire Intersection Begins at 12:15													
12:15	307	0	0	307	0	381	0	381	0	0	0	0	688
12:30	334	0	0	334	0	349	2	351	0	0	0	0	685
12:45	310	0	0	310	0	371	1	372	0	0	0	0	682
13:00	350	0	0	350	0	375	4	379	0	0	0	0	729
Total Volume	1301	0	0	1301	0	1476	7	1483	0	0	0	0	2784
% App. Total	100	0	0		0	99.5	0.5		0	0	0		
PHF	.929	.000	.000	.929	.000	.969	.438	.973	.000	.000	.000	.000	.955
Automobiles	1253	0	0	1253	0	1389	7	1396	0	0	0	0	2649
% Automobiles	96.3	0	0	96.3	0	94.1	100	94.1	0	0	0	0	95.2
Trucks	48	0	0	48	0	87	0	87	0	0	0	0	135
% Trucks	3.7	0	0	3.7	0	5.9	0	5.9	0	0	0	0	4.8
Buses	0	0	0	0	0	0	0	0	0	0	0	0	0
% Buses	0	0	0	0	0	0	0	0	0	0	0	0	0

Peak Hour Analysis From 09:00 to 13:00 - Peak 1 of 1
Peak Hour for Each Approach Begins at:

	09:15				12:15				09:00			
+0 mins.	316	0	0	316	0	381	0	381	0	0	0	0
+15 mins.	345	0	0	345	0	349	2	351	0	0	0	0
+30 mins.	342	0	1	343	0	371	1	372	0	0	0	0
+45 mins.	348	0	0	348	0	375	4	379	0	1	0	1
Total Volume	1351	0	1	1352	0	1476	7	1483	0	1	0	1
% App. Total	99.9	0	0.1		0	99.5	0.5		0	100	0	
PHF	.971	.000	.250	.971	.000	.969	.438	.973	.000	.250	.000	.250
Automobiles	1271	0	1	1272	0	1389	7	1396	0	1	0	1
% Automobiles	94.1	0	100	94.1	0	94.1	100	94.1	0	100	0	100
Trucks	78	0	0	78	0	87	0	87	0	0	0	0
% Trucks	5.8	0	0	5.8	0	5.9	0	5.9	0	0	0	0
Buses	2	0	0	2	0	0	0	0	0	0	0	0
% Buses	0.1	0	0	0.1	0	0	0	0	0	0	0	0

Peak Hour Analysis From 13:15 to 16:45 - Peak 1 of 1
Peak Hour for Entire Intersection Begins at 15:15

15:15	366	0	0	366	1	443	0	444	2	0	0	2	812
15:30	383	0	0	383	0	401	3	404	5	0	0	5	792
15:45	357	1	0	358	0	421	3	424	0	1	0	1	783
16:00	328	0	0	328	0	476	0	476	0	0	0	0	804
Total Volume	1434	1	0	1435	1	1741	6	1748	7	1	0	8	3191
% App. Total	99.9	0.1	0		0.1	99.6	0.3		87.5	12.5	0		
PHF	.936	.250	.000	.937	.250	.914	.500	.918	.350	.250	.000	.400	.982
Automobiles	1393	1	0	1394	1	1619	6	1626	6	1	0	7	3027
% Automobiles	97.1	100	0	97.1	100	93.0	100	93.0	85.7	100	0	87.5	94.9
Trucks	34	0	0	34	0	110	0	110	1	0	0	1	145
% Trucks	2.4	0	0	2.4	0	6.3	0	6.3	14.3	0	0	12.5	4.5
Buses	7	0	0	7	0	12	0	12	0	0	0	0	19
% Buses	0.5	0	0	0.5	0	0.7	0	0.7	0	0	0	0	0.6

Intersection Turning Movement Count

SR 951/Collier Blvd @ Median Break
n/o Championship Dr

File Name : 21076-1
Site Code : 21076-1
Start Date : 5/5/2021
Page No : 4

Start Time	SR 951/Collier Blvd Southbound				SR 951/Collier Blvd Northbound				Belle Meade Service Center Eastbound				Int. Total
	Thru	Right	Utrns	App. Total	Left	Thru	Utrns	App. Total	Left	Right	Utrns	App. Total	
Peak Hour Analysis From 13:15 to 16:45 - Peak 1 of 1													
Peak Hour for Each Approach Begins at:													
	15:00				16:00				15:00				
+0 mins.	331	0	0	331	0	476	0	476	0	0	0	0	0
+15 mins.	366	0	0	366	0	468	3	471	2	0	0	0	2
+30 mins.	383	0	0	383	0	439	2	441	5	0	0	0	5
+45 mins.	357	1	0	358	0	445	1	446	0	1	0	0	1
Total Volume	1437	1	0	1438	0	1828	6	1834	7	1	0	0	8
% App. Total	99.9	0.1	0		0	99.7	0.3		87.5	12.5	0		
PHF	.938	.250	.000	.939	.000	.960	.500	.963	.350	.250	.000	.400	
Automobiles	1392	1	0	1393	0	1735	6	1741	6	1	0	0	7
% Automobiles	96.9	100	0	96.9	0	94.9	100	94.9	85.7	100	0	0	87.5
Trucks	36	0	0	36	0	85	0	85	1	0	0	0	1
% Trucks	2.5	0	0	2.5	0	4.6	0	4.6	14.3	0	0	0	12.5
Buses	9	0	0	9	0	8	0	8	0	0	0	0	0
% Buses	0.6	0	0	0.6	0	0.4	0	0.4	0	0	0	0	0

Intersection Turning Movement Count

SR 951/Collier Blvd @ Median Break
n/o Championship Dr

File Name : 21076-1
Site Code : 21076-1
Start Date : 5/5/2021
Page No : 1

Groups Printed- Trucks - Buses

Start Time	SR 951/Collier Blvd Southbound				SR 951/Collier Blvd Northbound				Belle Meade Service Center Eastbound				Int. Total
	Thru	Right	Utrns	App. Total	Left	Thru	Utrns	App. Total	Left	Right	Utrns	App. Total	
09:00	20	0	0	20	0	16	0	16	0	0	0	0	36
09:15	20	0	0	20	0	24	0	24	0	0	0	0	44
09:30	17	0	0	17	0	14	0	14	0	0	0	0	31
09:45	23	0	0	23	0	25	0	25	0	0	0	0	48
Total	80	0	0	80	0	79	0	79	0	0	0	0	159
10:00	20	0	0	20	0	25	0	25	0	0	0	0	45
10:15	21	0	0	21	0	18	1	19	0	0	0	0	40
10:30	17	0	0	17	0	26	0	26	0	0	0	0	43
10:45	22	0	0	22	0	16	0	16	0	0	0	0	38
Total	80	0	0	80	0	85	1	86	0	0	0	0	166
11:00	16	0	0	16	0	20	1	21	0	0	0	0	37
11:15	13	0	0	13	0	20	0	20	0	0	0	0	33
11:30	13	0	0	13	0	13	0	13	0	0	0	0	26
11:45	13	0	0	13	0	21	0	21	0	0	0	0	34
Total	55	0	0	55	0	74	1	75	0	0	0	0	130
12:00	17	0	0	17	0	18	0	18	0	0	0	0	35
12:15	16	0	0	16	0	22	0	22	0	0	0	0	38
12:30	13	0	0	13	0	28	0	28	0	0	0	0	41
12:45	10	0	0	10	0	18	0	18	0	0	0	0	28
Total	56	0	0	56	0	86	0	86	0	0	0	0	142
13:00	9	0	0	9	0	19	0	19	0	0	0	0	28
13:15	13	0	0	13	1	13	0	14	0	0	0	0	27
13:30	13	0	0	13	2	22	1	25	0	0	0	0	38
13:45	14	0	0	14	0	14	0	14	1	0	0	1	29
Total	49	0	0	49	3	68	1	72	1	0	0	1	122
14:00	17	0	0	17	2	17	0	19	0	0	0	0	36
14:15	14	0	0	14	0	30	0	30	0	0	0	0	44
14:30	6	0	0	6	0	35	0	35	0	0	0	0	41
14:45	7	0	0	7	0	28	0	28	0	0	0	0	35
Total	44	0	0	44	2	110	0	112	0	0	0	0	156
15:00	13	0	0	13	0	29	0	29	0	0	0	0	42
15:15	12	0	0	12	0	28	0	28	0	0	0	0	40
15:30	9	0	0	9	0	30	0	30	1	0	0	1	40
15:45	11	0	0	11	0	35	0	35	0	0	0	0	46
Total	45	0	0	45	0	122	0	122	1	0	0	1	168
16:00	9	0	0	9	0	29	0	29	0	0	0	0	38
16:15	7	0	0	7	0	25	0	25	0	0	0	0	32
16:30	6	0	0	6	0	28	0	28	0	0	0	0	34
16:45	11	0	0	11	0	11	0	11	0	0	0	0	22
Total	33	0	0	33	0	93	0	93	0	0	0	0	126
Grand Total	442	0	0	442	5	717	3	725	2	0	0	2	1169
Apprch %	100	0	0		0.7	98.9	0.4		100	0	0		
Total %	37.8	0	0	37.8	0.4	61.3	0.3	62	0.2	0	0	0.2	
Trucks	414	0	0	414	5	693	2	700	2	0	0	2	1116
% Trucks	93.7	0	0	93.7	100	96.7	66.7	96.6	100	0	0	100	95.5
Buses	28	0	0	28	0	24	1	25	0	0	0	0	53
% Buses	6.3	0	0	6.3	0	3.3	33.3	3.4	0	0	0	0	4.5

Pedestrian/Bicycle Count Field Data Sheet

Date: May 5, 2021 Day: Wednesday

Count Times: 9AM-5PM Weather: Clear

Intersection: SR 951/Collier Blvd @ Median Break n/o Championship Dr

Comments: _____

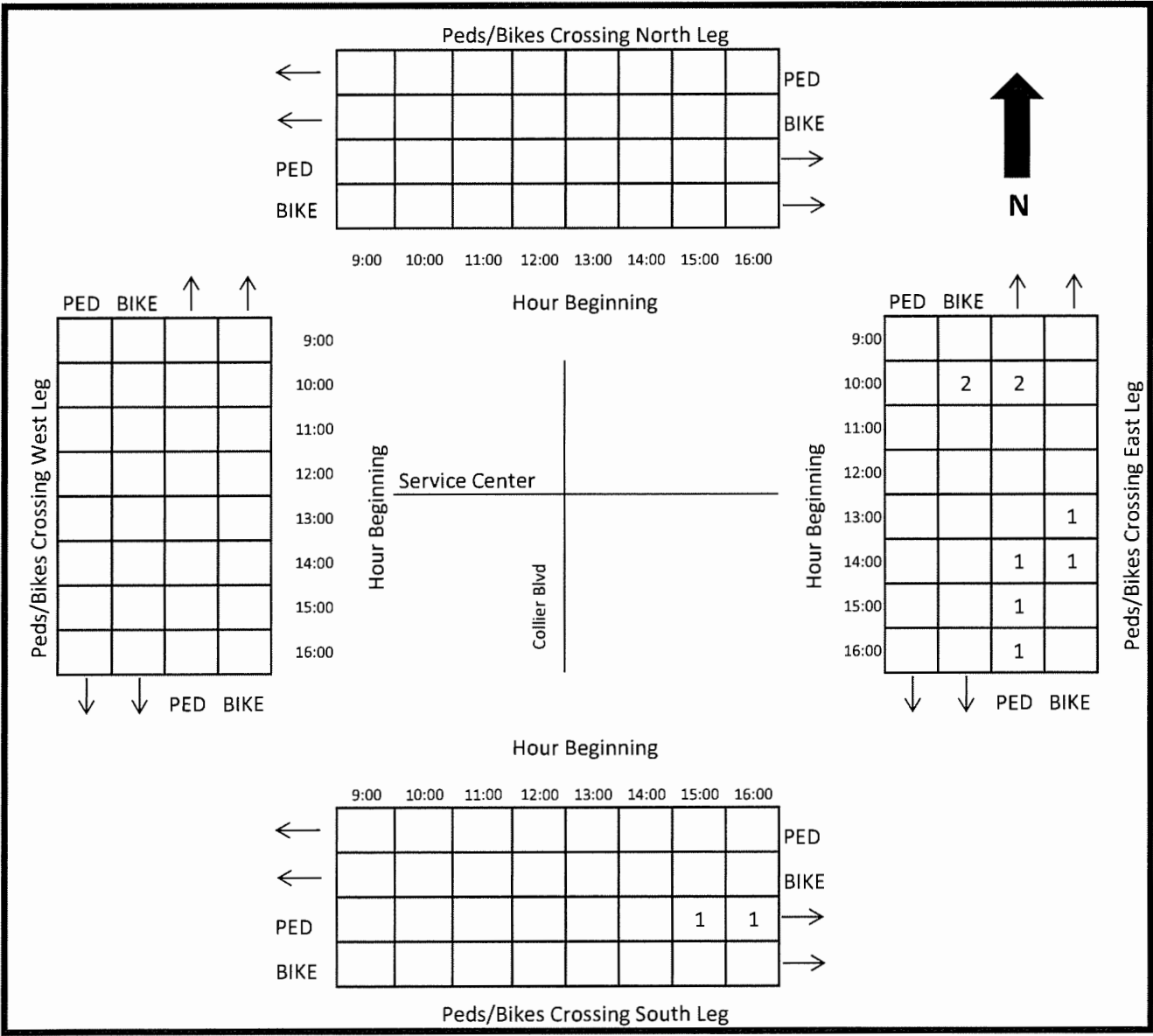

↑

N

Peds/Bikes Crossing West Leg

Peds/Bikes Crossing East Leg

APPENDIX C

Delay Data

Burgess & Niple, Inc.

10006 N. Dale Mabry Hwy, Suite 201
Tampa, FL 33618
(813) 962-8689

SR 951 at Championship Dr
Section: 03030 MP:7.578
Weather: Clear
County: Collier

File Name : 102_SR 951 at Championship Dr (WB) AM
Site Code : 00000102
Start Date : 2/18/2021
Page No : 1

L n.	No.	Joined Queue	Released From Queue	Delay	
1	1	10:00:01 AM	10:00:10 AM	9	
1	2	10:00:01 AM	10:00:18 AM	17	
1	3	10:00:02 AM	10:00:41 AM	39	
1	4	10:00:02 AM	10:00:47 AM	45	
1	5	10:00:02 AM	10:00:53 AM	51	
1	6	10:00:02 AM	10:00:58 AM	56	
1	7	10:00:03 AM	10:01:12 AM	69	
1	8	10:00:03 AM	10:01:14 AM	71	
1	9	10:00:03 AM	10:01:19 AM	76	
1	10	10:00:03 AM	10:01:26 AM	83	
1	11	10:00:03 AM	10:01:32 AM	89	
1	12	10:00:04 AM	10:01:35 AM	91	
1	13	10:00:04 AM	10:02:05 AM	121	
1	14	10:00:48 AM	10:02:12 AM	84	
1	15	10:00:49 AM	10:02:38 AM	109	
1	16	10:00:49 AM	10:02:59 AM	130	
1	17	10:00:50 AM	10:03:09 AM	139	
1	18	10:01:43 AM	10:03:25 AM	102	
1	19	10:01:43 AM	10:03:29 AM	106	
1	20	10:01:43 AM	10:03:32 AM	109	
1	21	10:01:44 AM	10:03:38 AM	114	
1	22	10:01:44 AM	10:03:43 AM	119	
1	23	10:02:43 AM	10:03:48 AM	65	
1	24	10:03:11 AM	10:03:57 AM	46	
1	25	10:03:11 AM	10:04:01 AM	50	
1	26	10:03:51 AM	10:04:29 AM	38	
1	27	10:03:51 AM	10:04:31 AM	40	
1	28	10:03:51 AM	10:04:40 AM	49	
1	29	10:03:53 AM	10:04:45 AM	52	
1	30	10:03:54 AM	10:04:56 AM	62	
1	31	10:03:54 AM	10:05:04 AM	70	
1	32	10:04:23 AM	10:05:22 AM	59	
1	33	10:04:23 AM	10:05:29 AM	66	
1	34	10:04:53 AM	10:05:46 AM	53	
1	35	10:04:54 AM	10:05:55 AM	61	
1	36	10:05:19 AM	10:06:05 AM	46	
1	37	10:05:19 AM	10:06:14 AM	55	
1	38	10:05:47 AM	10:06:19 AM	32	
1	39	10:05:48 AM	10:06:27 AM	39	
1	40	10:05:49 AM	10:06:37 AM	48	
1	41	10:06:07 AM	10:06:41 AM	34	
1	42	10:06:09 AM	10:06:45 AM	36	
1	43	10:06:32 AM	10:06:52 AM	20	
1	44	10:06:32 AM	10:07:07 AM	35	
1	45	10:06:33 AM	10:07:12 AM	39	
1	46	10:06:36 AM	10:07:15 AM	39	
1	47	10:06:37 AM	10:07:30 AM	53	
1	48	10:06:46 AM	10:07:36 AM	50	
1	49	10:06:47 AM	10:07:44 AM	57	
1	50	10:06:47 AM	10:07:54 AM	67	
1	51	10:06:49 AM	10:08:20 AM	91	
1	52	10:06:50 AM	10:08:25 AM	95	
1	53	10:07:43 AM	10:08:34 AM	51	
1	54	10:07:43 AM	10:08:48 AM	65	
1	55	10:08:07 AM	10:08:51 AM	44	
1	56	10:08:07 AM	10:09:08 AM	61	
1	57	10:08:07 AM	10:09:13 AM	66	
1	58	10:08:08 AM	10:09:29 AM	81	
1	59	10:08:36 AM	10:09:30 AM	54	

Burgess & Niple, Inc.

10006 N. Dale Mabry Hwy, Suite 201
Tampa, FL 33618
(813) 962-8689

SR 951 at Championship Dr
Section: 03030 MP:7.578
Weather: Clear
County: Collier

File Name : 102_SR 951 at Championship Dr (WB) AM
Site Code : 00000102
Start Date : 2/18/2021
Page No : 2

L n.	No.	Joined Queue	Released From Queue	Delay	
1	60	10:08:37 AM	10:09:35 AM	58	
1	61	10:08:44 AM	10:09:39 AM	55	
1	62	10:08:44 AM	10:09:46 AM	62	
1	63	10:09:16 AM	10:09:53 AM	37	
1	64	10:09:16 AM	10:09:55 AM	39	
1	65	10:09:17 AM	10:10:50 AM	93	
1	66	10:09:18 AM	10:10:53 AM	95	
1	67	10:09:48 AM	10:11:02 AM	74	
1	68	10:09:48 AM	10:11:07 AM	79	
1	69	10:09:48 AM	10:11:30 AM	102	
1	70	10:09:48 AM	10:11:32 AM	104	
1	71	10:09:49 AM	10:11:33 AM	104	
1	72	10:11:00 AM	10:11:35 AM	35	
1	73	10:11:00 AM	10:11:38 AM	38	
1	74	10:11:01 AM	10:11:46 AM	45	
1	75	10:11:21 AM	10:12:00 AM	39	
1	76	10:11:22 AM	10:12:07 AM	45	
1	77	10:11:41 AM	10:12:09 AM	28	
1	78	10:11:42 AM	10:12:19 AM	37	
1	79	10:11:42 AM	10:12:22 AM	40	
1	80	10:11:43 AM	10:12:27 AM	44	
1	81	10:12:16 AM	10:12:38 AM	22	
1	82	10:12:16 AM	10:12:43 AM	27	
1	83	10:12:16 AM	10:12:48 AM	32	
1	84	10:12:17 AM	10:12:53 AM	36	
1	85	10:12:17 AM	10:12:59 AM	42	
1	86	10:12:32 AM	10:13:14 AM	42	
1	87	10:12:32 AM	10:13:15 AM	43	
1	88	10:12:33 AM	10:13:27 AM	54	
1	89	10:12:54 AM	10:13:38 AM	44	
1	90	10:12:55 AM	10:13:45 AM	50	
1	91	10:12:55 AM	10:13:47 AM	52	
1	92	10:12:58 AM	10:13:50 AM	52	
1	93	10:13:31 AM	10:13:59 AM	28	
1	94	10:13:32 AM	10:14:02 AM	30	
1	95	10:13:33 AM	10:14:11 AM	38	
1	96	10:13:33 AM	10:14:14 AM	41	
1	97	10:13:52 AM	10:14:22 AM	30	
1	98	10:13:53 AM	10:14:28 AM	35	
1	99	10:13:53 AM	10:14:31 AM	38	
1	100	10:13:53 AM	10:14:37 AM	44	
1	101	10:13:54 AM	10:14:43 AM	49	
1	102	10:13:54 AM	10:14:50 AM	56	
1	103	10:14:24 AM	10:14:59 AM	35	
1	104	10:14:25 AM	10:15:04 AM	39	
1	105	10:14:25 AM	10:15:11 AM	46	
1	106	10:14:46 AM	10:15:22 AM	36	
1	107	10:14:46 AM	10:15:24 AM	38	
1	108	10:14:47 AM	10:15:34 AM	47	
1	109	10:14:47 AM	10:15:48 AM	61	
1	110	10:14:47 AM	10:15:54 AM	67	
1	111	10:14:48 AM	10:16:00 AM	72	
1	112	10:14:48 AM	10:16:05 AM	77	
1	113	10:15:19 AM	10:16:10 AM	51	
1	114	10:15:29 AM	10:16:16 AM	47	
1	115	10:15:29 AM	10:16:20 AM	51	
1	116	10:15:50 AM	10:16:32 AM	42	
1	117	10:15:51 AM	10:16:43 AM	52	
1	118	10:15:51 AM	10:16:51 AM	60	
1	119	10:15:52 AM	10:17:09 AM	77	
1	120	10:16:35 AM	10:17:11 AM	36	

Burgess & Niple, Inc.

10006 N. Dale Mabry Hwy, Suite 201
Tampa, FL 33618
(813) 962-8689

SR 951 at Championship Dr
Section: 03030 MP:7.578
Weather: Clear
County: Collier

File Name : 102_SR 951 at Championship Dr (WB) AM
Site Code : 00000102
Start Date : 2/18/2021
Page No : 3

L n.	No.	Joined Queue	Released From Queue	Delay	
1	121	10:16:35 AM	10:17:15 AM	40	
1	122	10:16:36 AM	10:17:20 AM	44	
1	123	10:17:00 AM	10:17:22 AM	22	
1	124	10:17:01 AM	10:17:30 AM	29	
1	125	10:17:04 AM	10:17:34 AM	30	
1	126	10:17:04 AM	10:17:52 AM	48	
1	127	10:17:24 AM	10:17:55 AM	31	
1	128	10:17:24 AM	10:17:56 AM	32	
1	129	10:17:25 AM	10:17:59 AM	34	
1	130	10:17:25 AM	10:18:04 AM	39	
1	131	10:17:25 AM	10:18:12 AM	47	
1	132	10:17:26 AM	10:18:14 AM	48	
1	133	10:18:02 AM	10:18:27 AM	25	
1	134	10:18:17 AM	10:18:31 AM	14	
1	135	10:18:19 AM	10:18:38 AM	19	
1	136	10:18:36 AM	10:18:47 AM	11	
1	137	10:18:37 AM	10:18:57 AM	20	
1	138	10:18:55 AM	10:19:02 AM	7	
1	139	10:19:28 AM	10:19:34 AM	6	
1	140	10:19:41 AM	10:19:47 AM	6	
1	141	10:19:46 AM	10:20:07 AM	21	
1	142	10:19:55 AM	10:20:08 AM	13	
1	143	10:20:00 AM	10:20:19 AM	19	
1	144	10:20:02 AM	10:20:27 AM	25	
1	145	10:20:06 AM	10:20:46 AM	40	
1	146	10:20:14 AM	10:20:53 AM	39	
1	147	10:20:29 AM	10:20:59 AM	30	
1	148	10:20:30 AM	10:21:09 AM	39	
1	149	10:21:14 AM	10:21:32 AM	18	
1	150	10:21:18 AM	10:21:49 AM	31	
1	151	10:21:19 AM	10:21:58 AM	39	
1	152	10:21:21 AM	10:22:00 AM	39	
1	153	10:21:55 AM	10:22:08 AM	13	
1	154	10:21:55 AM	10:22:15 AM	20	
1	155	10:21:57 AM	10:22:16 AM	19	
1	156	10:22:11 AM	10:22:26 AM	15	
1	157	10:22:11 AM	10:22:48 AM	37	
1	158	10:22:12 AM	10:22:52 AM	40	
1	159	10:22:13 AM	10:22:56 AM	43	
1	160	10:22:33 AM	10:22:59 AM	26	
1	161	10:22:34 AM	10:23:01 AM	27	
1	162	10:22:58 AM	10:23:06 AM	8	
1	163	10:22:58 AM	10:23:24 AM	26	
1	164	10:23:07 AM	10:23:32 AM	25	
1	165	10:23:11 AM	10:23:42 AM	31	
1	166	10:23:13 AM	10:23:43 AM	30	
1	167	10:23:36 AM	10:23:45 AM	9	
1	168	10:23:37 AM	10:23:48 AM	11	
1	169	10:23:37 AM	10:24:36 AM	59	
1	170	10:23:55 AM	10:24:48 AM	53	
1	171	10:24:16 AM	10:24:55 AM	39	
1	172	10:24:21 AM	10:25:00 AM	39	
1	173	10:24:31 AM	10:25:06 AM	35	
1	174	10:24:58 AM	10:25:08 AM	10	
1	175	10:25:04 AM	10:25:47 AM	43	
1	176	10:25:09 AM	10:26:15 AM	66	
1	177	10:25:10 AM	10:26:17 AM	67	
1	178	10:25:19 AM	10:26:19 AM	60	
1	179	10:25:45 AM	10:26:27 AM	42	
1	180	10:26:05 AM	10:26:35 AM	30	
1	181	10:26:25 AM	10:27:06 AM	41	

Burgess & Niple, Inc.

10006 N. Dale Mabry Hwy, Suite 201
Tampa, FL 33618
(813) 962-8689

SR 951 at Championship Dr
Section: 03030 MP:7.578
Weather: Clear
County: Collier

File Name : 102_SR 951 at Championship Dr (WB) AM
Site Code : 00000102
Start Date : 2/18/2021
Page No : 4

L n.	No.	Joined Queue	Released From Queue	Delay	
1	182	10:26:26 AM	10:27:11 AM	45	
1	183	10:26:35 AM	10:27:26 AM	51	
1	184	10:27:04 AM	10:28:00 AM	56	
1	185	10:27:17 AM	10:28:02 AM	45	
1	186	10:27:32 AM	10:28:04 AM	32	
1	187	10:27:36 AM	10:28:06 AM	30	
1	188	10:28:01 AM	10:28:11 AM	10	
1	189	10:28:01 AM	10:28:21 AM	20	
1	190	10:28:08 AM	10:28:22 AM	14	
1	191	10:28:09 AM	10:28:34 AM	25	
1	192	10:28:09 AM	10:29:08 AM	59	
1	193	10:28:10 AM	10:29:11 AM	61	
1	194	10:28:16 AM	10:29:13 AM	57	
1	195	10:28:35 AM	10:29:21 AM	46	
1	196	10:28:36 AM	10:29:26 AM	50	
1	197	10:28:57 AM	10:29:28 AM	31	
1	198	10:29:02 AM	10:29:33 AM	31	
1	199	10:29:03 AM	10:29:36 AM	33	
1	200	10:29:24 AM	10:29:47 AM	23	
1	201	10:29:24 AM	10:29:49 AM	25	
1	202	10:29:24 AM	10:29:51 AM	27	
1	203	10:29:26 AM	10:29:57 AM	31	
1	204	10:29:42 AM	10:30:00 AM	18	
1	205	10:29:42 AM	10:30:05 AM	23	
1	206	10:30:02 AM	10:30:07 AM	5	
1	207	10:30:02 AM	10:30:12 AM	10	
1	208	10:30:02 AM	10:30:32 AM	30	
1	209	10:30:02 AM	10:30:33 AM	31	
1	210	10:30:03 AM	10:30:51 AM	48	
1	211	10:30:03 AM	10:30:57 AM	54	
1	212	10:30:03 AM	10:31:12 AM	69	
1	213	10:30:18 AM	10:31:14 AM	56	
1	214	10:31:01 AM	10:31:20 AM	19	
1	215	10:31:02 AM	10:31:34 AM	32	
1	216	10:31:02 AM	10:31:59 AM	57	
1	217	10:31:03 AM	10:32:04 AM	61	
1	218	10:31:27 AM	10:32:20 AM	53	
1	219	10:31:29 AM	10:32:31 AM	62	
1	220	10:31:58 AM	10:32:33 AM	35	
1	221	10:31:58 AM	10:32:41 AM	43	
1	222	10:32:28 AM	10:32:44 AM	16	
1	223	10:32:38 AM	10:32:51 AM	13	
1	224	10:32:39 AM	10:32:55 AM	16	
1	225	10:32:39 AM	10:33:02 AM	23	
1	226	10:32:39 AM	10:33:08 AM	29	
1	227	10:32:39 AM	10:33:23 AM	44	
1	228	10:32:40 AM	10:33:25 AM	45	
1	229	10:32:41 AM	10:33:32 AM	51	
1	230	10:33:05 AM	10:33:37 AM	32	
1	231	10:33:05 AM	10:33:44 AM	39	
1	232	10:33:06 AM	10:33:46 AM	40	
1	233	10:33:33 AM	10:33:49 AM	16	
1	234	10:33:33 AM	10:33:52 AM	19	
1	235	10:33:34 AM	10:33:55 AM	21	
1	236	10:33:57 AM	10:34:08 AM	11	
1	237	10:33:57 AM	10:34:10 AM	13	
1	238	10:33:58 AM	10:35:58 AM	120	
1	239	10:33:58 AM	10:35:58 AM	120	
1	240	10:33:58 AM	10:36:00 AM	122	
1	241	10:33:58 AM	10:36:07 AM	129	
1	242	10:33:59 AM	10:36:08 AM	129	

Burgess & Niple, Inc.

10006 N. Dale Mabry Hwy, Suite 201
Tampa, FL 33618
(813) 962-8689

SR 951 at Championship Dr
Section: 03030 MP:7.578
Weather: Clear
County: Collier

File Name : 102_SR 951 at Championship Dr (WB) AM
Site Code : 00000102
Start Date : 2/18/2021
Page No : 5

L n.	No.	Joined Queue	Released From Queue	Delay	
1	243	10:35:07 AM	10:36:17 AM	70	
1	244	10:36:04 AM	10:36:25 AM	21	
1	245	10:36:05 AM	10:36:43 AM	38	
1	246	10:36:27 AM	10:36:44 AM	17	
1	247	10:36:28 AM	10:37:27 AM	59	
1	248	10:36:28 AM	10:37:34 AM	66	
1	249	10:36:52 AM	10:37:37 AM	45	
1	250	10:36:53 AM	10:37:49 AM	56	
1	251	10:36:53 AM	10:37:55 AM	62	
1	252	10:36:54 AM	10:37:58 AM	64	
1	253	10:37:18 AM	10:38:01 AM	43	
1	254	10:37:19 AM	10:38:11 AM	52	
1	255	10:37:47 AM	10:38:12 AM	25	
1	256	10:37:47 AM	10:38:16 AM	29	
1	257	10:37:48 AM	10:38:19 AM	31	
1	258	10:38:10 AM	10:38:21 AM	11	
1	259	10:38:10 AM	10:38:24 AM	14	
1	260	10:38:32 AM	10:38:38 AM	6	
1	261	10:38:33 AM	10:38:56 AM	23	
1	262	10:38:57 AM	10:39:23 AM	26	
1	263	10:39:09 AM	10:39:26 AM	17	
1	264	10:39:11 AM	10:39:35 AM	24	
1	265	10:39:19 AM	10:39:40 AM	21	
1	266	10:39:33 AM	10:39:43 AM	10	
1	267	10:39:33 AM	10:39:46 AM	13	
1	268	10:39:38 AM	10:39:51 AM	13	
1	269	10:39:44 AM	10:39:53 AM	9	
1	270	10:39:49 AM	10:39:57 AM	8	
1	271	10:39:49 AM	10:40:03 AM	14	
1	272	10:40:08 AM	10:40:17 AM	9	
1	273	10:40:12 AM	10:40:20 AM	8	
1	274	10:40:15 AM	10:40:44 AM	29	
1	275	10:40:21 AM	10:40:46 AM	25	
1	276	10:40:29 AM	10:40:47 AM	18	
1	277	10:40:33 AM	10:41:02 AM	29	
1	278	10:40:41 AM	10:41:05 AM	24	
1	279	10:40:43 AM	10:41:11 AM	28	
1	280	10:40:51 AM	10:41:12 AM	21	
1	281	10:40:51 AM	10:41:17 AM	26	
1	282	10:41:08 AM	10:41:24 AM	16	
1	283	10:41:08 AM	10:41:45 AM	37	
1	284	10:41:09 AM	10:41:49 AM	40	
1	285	10:41:44 AM	10:41:52 AM	8	
1	286	10:42:08 AM	10:42:37 AM	29	
1	287	10:42:18 AM	10:42:40 AM	22	
1	288	10:42:21 AM	10:42:44 AM	23	
1	289	10:42:31 AM	10:42:51 AM	20	
1	290	10:42:52 AM	10:43:26 AM	34	
1	291	10:42:52 AM	10:43:35 AM	43	
1	292	10:42:53 AM	10:43:35 AM	42	
1	293	10:42:54 AM	10:43:37 AM	43	
1	294	10:43:00 AM	10:43:39 AM	39	
1	295	10:43:24 AM	10:43:43 AM	19	
1	296	10:43:33 AM	10:43:46 AM	13	
1	297	10:43:34 AM	10:43:49 AM	15	
1	298	10:43:50 AM	10:43:58 AM	8	
1	299	10:43:50 AM	10:44:02 AM	12	
1	300	10:43:51 AM	10:44:33 AM	42	
1	301	10:43:51 AM	10:44:39 AM	48	
1	302	10:43:52 AM	10:44:42 AM	50	
1	303	10:44:16 AM	10:44:47 AM	31	

Burgess & Niple, Inc.

10006 N. Dale Mabry Hwy, Suite 201
Tampa, FL 33618
(813) 962-8689

SR 951 at Championship Dr
Section: 03030 MP:7.578
Weather: Clear
County: Collier

File Name : 102_SR 951 at Championship Dr (WB) AM
Site Code : 00000102
Start Date : 2/18/2021
Page No : 6

L n.	No.	Joined Queue	Released From Queue	Delay	
1	304	10:44:18 AM	10:44:49 AM	31	
1	305	10:44:55 AM	10:45:02 AM	7	
1	306	10:45:07 AM	10:45:10 AM	3	
1	307	10:45:20 AM	10:45:25 AM	5	
1	308	10:45:24 AM	10:45:27 AM	3	
1	309	10:45:46 AM	10:45:49 AM	3	
1	310	10:45:59 AM	10:46:01 AM	2	
1	311	10:46:06 AM	10:46:45 AM	39	
1	312	10:46:07 AM	10:46:49 AM	42	
1	313	10:46:12 AM	10:46:53 AM	41	
1	314	10:46:13 AM	10:47:31 AM	78	
1	315	10:46:18 AM	10:47:35 AM	77	
1	316	10:46:33 AM	10:47:37 AM	64	
1	317	10:46:58 AM	10:47:40 AM	42	
1	318	10:46:58 AM	10:47:56 AM	58	
1	319	10:47:02 AM	10:47:59 AM	57	
1	320	10:47:29 AM	10:48:03 AM	34	
1	321	10:47:52 AM	10:48:14 AM	22	
1	322	10:47:54 AM	10:48:16 AM	22	
1	323	10:48:04 AM	10:48:19 AM	15	
1	324	10:48:05 AM	10:48:39 AM	34	
1	325	10:48:19 AM	10:48:41 AM	22	
1	326	10:48:32 AM	10:48:53 AM	21	
1	327	10:48:33 AM	10:49:13 AM	40	
1	328	10:48:44 AM	10:49:29 AM	45	
1	329	10:48:52 AM	10:49:31 AM	39	
1	330	10:49:12 AM	10:49:36 AM	24	
1	331	10:49:12 AM	10:49:51 AM	39	
1	332	10:49:33 AM	10:50:03 AM	30	
1	333	10:49:33 AM	10:50:23 AM	50	
1	334	10:49:34 AM	10:50:27 AM	53	
1	335	10:49:34 AM	10:50:33 AM	59	
1	336	10:50:02 AM	10:50:34 AM	32	
1	337	10:50:32 AM	10:50:40 AM	8	
1	338	10:50:32 AM	10:51:11 AM	39	
1	339	10:50:33 AM	10:51:13 AM	40	
1	340	10:50:38 AM	10:51:19 AM	41	
1	341	10:50:38 AM	10:51:30 AM	52	
1	342	10:50:54 AM	10:51:32 AM	38	
1	343	10:50:55 AM	10:51:38 AM	43	
1	344	10:51:18 AM	10:51:43 AM	25	
1	345	10:51:18 AM	10:51:45 AM	27	
1	346	10:51:29 AM	10:51:59 AM	30	
1	347	10:51:53 AM	10:52:00 AM	7	
1	348	10:52:43 AM	10:53:19 AM	36	
1	349	10:52:44 AM	10:53:25 AM	41	
1	350	10:52:45 AM	10:53:29 AM	44	
1	351	10:52:47 AM	10:53:32 AM	45	
1	352	10:52:52 AM	10:53:34 AM	42	
1	353	10:52:58 AM	10:53:37 AM	39	
1	354	10:53:11 AM	10:53:40 AM	29	
1	355	10:53:41 AM	10:53:43 AM	2	
1	356	10:53:41 AM	10:53:47 AM	6	
1	357	10:53:42 AM	10:54:07 AM	25	
1	358	10:53:42 AM	10:54:29 AM	47	
1	359	10:53:42 AM	10:54:30 AM	48	
1	360	10:54:08 AM	10:54:40 AM	32	
1	361	10:54:09 AM	10:54:51 AM	42	
1	362	10:54:20 AM	10:55:07 AM	47	
1	363	10:54:38 AM	10:55:17 AM	39	
1	364	10:54:39 AM	10:55:19 AM	40	

Burgess & Niple, Inc.

10006 N. Dale Mabry Hwy, Suite 201
Tampa, FL 33618
(813) 962-8689

SR 951 at Championship Dr
Section: 03030 MP:7.578
Weather: Clear
County: Collier

File Name : 102_SR 951 at Championship Dr (WB) AM
Site Code : 00000102
Start Date : 2/18/2021
Page No : 7

L n.	No.	Joined Queue	Released From Queue	Delay
1	365	10:55:11 AM	10:55:28 AM	17
1	366	10:55:30 AM	10:55:54 AM	24
1	367	10:55:47 AM	10:55:57 AM	10
1	368	10:56:09 AM	10:56:10 AM	1
1	369	10:56:14 AM	10:56:16 AM	2
1	370	10:56:34 AM	10:56:43 AM	9
1	371	10:57:04 AM	10:57:45 AM	41
1	372	10:57:05 AM	10:57:48 AM	43
1	373	10:57:06 AM	10:57:51 AM	45
1	374	10:57:51 AM	10:57:58 AM	7
1	375	10:57:52 AM	10:58:00 AM	8
1	376	10:57:52 AM	10:58:02 AM	10
1	377	10:57:54 AM	10:58:09 AM	15
1	378	10:57:55 AM	10:58:10 AM	15
1	379	10:58:11 AM	10:58:43 AM	32
1	380	10:58:12 AM	10:58:46 AM	34
1	381	10:58:13 AM	10:58:51 AM	38
1	382	10:58:15 AM	10:59:27 AM	72
1	383	10:58:49 AM	10:59:29 AM	40
1	384	10:58:55 AM	10:59:32 AM	37
1	385	10:59:01 AM	10:59:34 AM	33
1	386	10:59:15 AM	10:59:39 AM	24
1	387	10:59:37 AM	10:59:45 AM	8
1	388	10:59:37 AM	10:59:46 AM	9
1	389	10:59:38 AM	10:59:48 AM	10
1	390	10:59:38 AM	10:59:53 AM	15
1	391	10:59:44 AM	10:59:54 AM	10
1	392	10:59:50 AM	10:59:56 AM	6

Summary Information:

10:00:00 AM - 11:00:00 AM	Lane 1
Total Vehicle Count:	392
Delayed Vehicle Count:	392
Through Vehicle Count:	0
Average Stopped Time:	40.14
Maximum Stopped Time:	139
Min. Secs. for Delay:	0
Average Queue:	4.38
Queue Density:	4.68
Maximum Queue:	13
Delay in Vehicle Hour:	4.38
Total Delay:	15735

Burgess & Niple, Inc.

10006 N. Dale Mabry Hwy, Suite 201
Tampa, FL 33618
(813) 962-8689

SR 951 at Championship Dr
Section: 03030 MP: 7.578
Weather: Clear
County: Collier

File Name : 102_SR 951 at Championship Dr (WB) PM
Site Code : 00000102
Start Date : 2/18/2021
Page No : 1

L n.	No.	Joined Queue	Released From Queue	Delay	
1	1	2:00:00 PM	2:00:12 PM	12	
1	2	2:00:01 PM	2:00:32 PM	31	
1	3	2:00:01 PM	2:00:35 PM	34	
1	4	2:00:15 PM	2:00:38 PM	23	
1	5	2:00:17 PM	2:00:43 PM	26	
1	6	2:00:41 PM	2:00:45 PM	4	
1	7	2:00:42 PM	2:00:53 PM	11	
1	8	2:00:46 PM	2:00:55 PM	9	
1	9	2:00:48 PM	2:00:59 PM	11	
1	10	2:01:01 PM	2:01:03 PM	2	
1	11	2:01:26 PM	2:02:13 PM	47	
1	12	2:01:40 PM	2:02:14 PM	34	
1	13	2:01:49 PM	2:02:34 PM	45	
1	14	2:01:51 PM	2:02:36 PM	45	
1	15	2:01:54 PM	2:02:58 PM	64	
1	16	2:02:00 PM	2:03:11 PM	71	
1	17	2:02:32 PM	2:03:15 PM	43	
1	18	2:02:41 PM	2:03:21 PM	40	
1	19	2:03:05 PM	2:03:24 PM	19	
1	20	2:03:19 PM	2:03:26 PM	7	
1	21	2:03:20 PM	2:03:27 PM	7	
1	22	2:03:30 PM	2:03:33 PM	3	
1	23	2:03:31 PM	2:03:37 PM	6	
1	24	2:03:32 PM	2:03:39 PM	7	
1	25	2:03:32 PM	2:03:42 PM	10	
1	26	2:03:44 PM	2:03:46 PM	2	
1	27	2:03:45 PM	2:03:52 PM	7	
1	28	2:03:45 PM	2:04:13 PM	28	
1	29	2:03:58 PM	2:04:33 PM	35	
1	30	2:03:59 PM	2:04:42 PM	43	
1	31	2:04:01 PM	2:04:45 PM	44	
1	32	2:04:07 PM	2:05:02 PM	55	
1	33	2:04:26 PM	2:05:39 PM	73	
1	34	2:04:26 PM	2:05:42 PM	76	
1	35	2:04:49 PM	2:05:45 PM	56	
1	36	2:04:50 PM	2:05:47 PM	57	
1	37	2:05:22 PM	2:05:53 PM	31	
1	38	2:05:22 PM	2:05:55 PM	33	
1	39	2:05:44 PM	2:05:58 PM	14	
1	40	2:05:44 PM	2:06:06 PM	22	
1	41	2:06:02 PM	2:06:17 PM	15	
1	42	2:06:02 PM	2:06:47 PM	45	
1	43	2:06:04 PM	2:06:50 PM	46	
1	44	2:06:05 PM	2:06:54 PM	49	
1	45	2:06:13 PM	2:07:10 PM	57	
1	46	2:06:13 PM	2:07:12 PM	59	
1	47	2:06:26 PM	2:07:19 PM	53	
1	48	2:07:01 PM	2:07:46 PM	45	
1	49	2:07:01 PM	2:08:00 PM	59	
1	50	2:07:02 PM	2:08:04 PM	62	
1	51	2:07:52 PM	2:08:13 PM	21	
1	52	2:08:11 PM	2:08:51 PM	40	
1	53	2:08:27 PM	2:08:55 PM	28	
1	54	2:08:28 PM	2:09:37 PM	69	
1	55	2:08:56 PM	2:09:38 PM	42	
1	56	2:08:57 PM	2:09:40 PM	43	
1	57	2:09:03 PM	2:09:44 PM	41	
1	58	2:09:42 PM	2:09:50 PM	8	
1	59	2:09:43 PM	2:09:53 PM	10	

Burgess & Niple, Inc.

10006 N. Dale Mabry Hwy, Suite 201
Tampa, FL 33618
(813) 962-8689

SR 951 at Championship Dr
Section: 03030 MP: 7.578
Weather: Clear
County: Collier

File Name : 102_SR 951 at Championship Dr (WB) PM
Site Code : 00000102
Start Date : 2/18/2021
Page No : 2

L n.	No.	Joined Queue	Released From Queue	Delay	
1	60	2:09:51 PM	2:09:57 PM	6	
1	61	2:09:54 PM	2:10:00 PM	6	
1	62	2:09:54 PM	2:10:05 PM	11	
1	63	2:09:56 PM	2:10:09 PM	13	
1	64	2:10:03 PM	2:10:11 PM	8	
1	65	2:10:04 PM	2:10:13 PM	9	
1	66	2:10:14 PM	2:10:15 PM	1	
1	67	2:10:16 PM	2:10:21 PM	5	
1	68	2:10:18 PM	2:10:22 PM	4	
1	69	2:10:19 PM	2:10:27 PM	8	
1	70	2:10:20 PM	2:10:34 PM	14	
1	71	2:10:35 PM	2:10:42 PM	7	
1	72	2:10:36 PM	2:11:14 PM	38	
1	73	2:10:38 PM	2:11:35 PM	57	
1	74	2:10:39 PM	2:11:39 PM	60	
1	75	2:10:44 PM	2:11:48 PM	64	
1	76	2:10:46 PM	2:11:51 PM	65	
1	77	2:10:47 PM	2:11:54 PM	67	
1	78	2:11:04 PM	2:11:57 PM	53	
1	79	2:11:05 PM	2:12:05 PM	60	
1	80	2:12:02 PM	2:12:12 PM	10	
1	81	2:12:03 PM	2:12:17 PM	14	
1	82	2:12:08 PM	2:12:59 PM	51	
1	83	2:12:12 PM	2:13:00 PM	48	
1	84	2:12:34 PM	2:13:11 PM	37	
1	85	2:12:36 PM	2:13:19 PM	43	
1	86	2:12:52 PM	2:13:24 PM	32	
1	87	2:13:07 PM	2:13:33 PM	26	
1	88	2:13:08 PM	2:13:36 PM	28	
1	89	2:13:29 PM	2:13:44 PM	15	
1	90	2:13:31 PM	2:13:46 PM	15	
1	91	2:13:40 PM	2:13:48 PM	8	
1	92	2:13:49 PM	2:14:05 PM	16	
1	93	2:13:50 PM	2:14:08 PM	18	
1	94	2:13:52 PM	2:14:10 PM	18	
1	95	2:13:56 PM	2:14:12 PM	16	
1	96	2:14:03 PM	2:14:14 PM	11	
1	97	2:14:03 PM	2:14:18 PM	15	
1	98	2:14:19 PM	2:14:36 PM	17	
1	99	2:14:20 PM	2:14:45 PM	25	
1	100	2:14:21 PM	2:15:06 PM	45	
1	101	2:14:23 PM	2:15:21 PM	58	
1	102	2:14:24 PM	2:15:23 PM	59	
1	103	2:14:35 PM	2:15:28 PM	53	
1	104	2:14:51 PM	2:15:36 PM	45	
1	105	2:14:51 PM	2:15:40 PM	49	
1	106	2:15:41 PM	2:15:44 PM	3	
1	107	2:15:45 PM	2:15:55 PM	10	
1	108	2:15:45 PM	2:15:56 PM	11	
1	109	2:15:46 PM	2:15:58 PM	12	
1	110	2:15:47 PM	2:16:01 PM	14	
1	111	2:15:49 PM	2:16:04 PM	15	
1	112	2:15:50 PM	2:16:45 PM	55	
1	113	2:16:09 PM	2:16:47 PM	38	
1	114	2:16:10 PM	2:16:54 PM	44	
1	115	2:16:12 PM	2:17:03 PM	51	
1	116	2:16:23 PM	2:17:39 PM	76	
1	117	2:16:57 PM	2:17:42 PM	45	
1	118	2:17:09 PM	2:17:46 PM	37	
1	119	2:17:14 PM	2:17:51 PM	37	
1	120	2:17:48 PM	2:18:05 PM	17	

Burgess & Niple, Inc.

10006 N. Dale Mabry Hwy, Suite 201
Tampa, FL 33618
(813) 962-8689

SR 951 at Championship Dr
Section: 03030 MP: 7.578
Weather: Clear
County: Collier

File Name : 102_SR 951 at Championship Dr (WB) PM
Site Code : 00000102
Start Date : 2/18/2021
Page No : 3

L n.	No.	Joined Queue	Released From Queue	Delay
1	121	2:17:57 PM	2:18:10 PM	13
1	122	2:18:11 PM	2:18:13 PM	2
1	123	2:18:14 PM	2:18:19 PM	5
1	124	2:18:26 PM	2:18:30 PM	4
1	125	2:18:47 PM	2:18:52 PM	5
1	126	2:18:49 PM	2:19:12 PM	23
1	127	2:18:51 PM	2:19:15 PM	24
1	128	2:18:51 PM	2:19:18 PM	27
1	129	2:18:55 PM	2:19:30 PM	35
1	130	2:19:01 PM	2:20:16 PM	75
1	131	2:19:04 PM	2:20:18 PM	74
1	132	2:19:22 PM	2:20:19 PM	57
1	133	2:19:22 PM	2:20:23 PM	61
1	134	2:20:05 PM	2:20:27 PM	22
1	135	2:20:07 PM	2:20:36 PM	29
1	136	2:20:25 PM	2:20:41 PM	16
1	137	2:20:26 PM	2:20:52 PM	26
1	138	2:20:35 PM	2:21:20 PM	45
1	139	2:20:40 PM	2:21:55 PM	75
1	140	2:21:06 PM	2:22:37 PM	91
1	141	2:21:23 PM	2:22:40 PM	77
1	142	2:21:29 PM	2:22:42 PM	73
1	143	2:21:43 PM	2:22:45 PM	62
1	144	2:21:46 PM	2:22:47 PM	61
1	145	2:22:06 PM	2:22:51 PM	45
1	146	2:22:36 PM	2:22:55 PM	19
1	147	2:22:57 PM	2:22:59 PM	2
1	148	2:22:58 PM	2:23:02 PM	4
1	149	2:22:59 PM	2:23:05 PM	6
1	150	2:23:03 PM	2:23:12 PM	9
1	151	2:23:09 PM	2:23:13 PM	4
1	152	2:23:10 PM	2:23:16 PM	6
1	153	2:23:11 PM	2:23:23 PM	12
1	154	2:23:11 PM	2:23:38 PM	27
1	155	2:23:34 PM	2:24:32 PM	58
1	156	2:23:42 PM	2:24:33 PM	51
1	157	2:23:49 PM	2:24:36 PM	47
1	158	2:23:51 PM	2:24:38 PM	47
1	159	2:23:54 PM	2:24:42 PM	48
1	160	2:23:56 PM	2:24:55 PM	59
1	161	2:24:44 PM	2:25:06 PM	22
1	162	2:24:47 PM	2:25:09 PM	22
1	163	2:24:49 PM	2:25:12 PM	23
1	164	2:24:52 PM	2:26:04 PM	72
1	165	2:25:03 PM	2:26:06 PM	63
1	166	2:25:29 PM	2:26:11 PM	42
1	167	2:25:33 PM	2:26:16 PM	43
1	168	2:26:03 PM	2:26:19 PM	16
1	169	2:26:04 PM	2:26:29 PM	25
1	170	2:26:20 PM	2:27:28 PM	68
1	171	2:26:22 PM	2:27:46 PM	84
1	172	2:26:45 PM	2:27:48 PM	63
1	173	2:26:52 PM	2:27:50 PM	58
1	174	2:26:54 PM	2:27:56 PM	62
1	175	2:27:01 PM	2:27:57 PM	56
1	176	2:27:53 PM	2:28:00 PM	7
1	177	2:27:56 PM	2:28:03 PM	7
1	178	2:28:05 PM	2:28:08 PM	3
1	179	2:28:07 PM	2:28:14 PM	7
1	180	2:28:23 PM	2:28:34 PM	11
1	181	2:28:32 PM	2:28:43 PM	11

Burgess & Niple, Inc.

10006 N. Dale Mabry Hwy, Suite 201
 Tampa, FL 33618
 (813) 962-8689

SR 951 at Championship Dr
 Section: 03030 MP: 7.578
 Weather: Clear
 County: Collier

File Name : 102_SR 951 at Championship Dr (WB) PM
 Site Code : 00000102
 Start Date : 2/18/2021
 Page No : 4

L n.	No.	Joined Queue	Released From Queue	Delay
1	182	2:28:49 PM	2:28:54 PM	5
1	183	2:29:16 PM	2:29:29 PM	13
1	184	2:29:24 PM	2:29:30 PM	6
1	185	2:29:26 PM	2:29:33 PM	7
1	186	2:29:27 PM	2:29:51 PM	24
1	187	2:29:40 PM	2:29:53 PM	13
1	188	2:29:44 PM	2:30:02 PM	18
1	189	2:29:49 PM	2:30:06 PM	17
1	190	2:30:03 PM	2:30:07 PM	4
1	191	2:30:13 PM	2:30:18 PM	5
1	192	2:30:16 PM	2:30:22 PM	6
1	193	2:30:39 PM	2:30:40 PM	1
1	194	2:30:52 PM	2:31:17 PM	25
1	195	2:31:24 PM	2:31:33 PM	9
1	196	2:31:46 PM	2:31:51 PM	5
1	197	2:31:57 PM	2:32:10 PM	13
1	198	2:31:58 PM	2:32:12 PM	14
1	199	2:32:09 PM	2:32:15 PM	6
1	200	2:32:33 PM	2:32:55 PM	22
1	201	2:32:50 PM	2:33:26 PM	36
1	202	2:33:28 PM	2:33:29 PM	1
1	203	2:33:37 PM	2:33:40 PM	3
1	204	2:33:38 PM	2:33:43 PM	5
1	205	2:33:47 PM	2:33:55 PM	8
1	206	2:34:14 PM	2:34:19 PM	5
1	207	2:34:28 PM	2:34:57 PM	29
1	208	2:34:34 PM	2:35:03 PM	29
1	209	2:34:52 PM	2:35:20 PM	28
1	210	2:35:02 PM	2:35:23 PM	21
1	211	2:35:28 PM	2:35:52 PM	24
1	212	2:35:29 PM	2:35:57 PM	28
1	213	2:35:57 PM	2:36:07 PM	10
1	214	2:36:06 PM	2:36:11 PM	5
1	215	2:36:12 PM	2:36:14 PM	2
1	216	2:36:17 PM	2:36:19 PM	2
1	217	2:36:19 PM	2:36:21 PM	2
1	218	2:36:29 PM	2:36:35 PM	6
1	219	2:36:44 PM	2:37:11 PM	27
1	220	2:36:47 PM	2:37:27 PM	40
1	221	2:36:53 PM	2:37:40 PM	47
1	222	2:36:56 PM	2:37:43 PM	47
1	223	2:37:14 PM	2:37:46 PM	32
1	224	2:37:32 PM	2:37:50 PM	18
1	225	2:37:48 PM	2:37:54 PM	6
1	226	2:37:49 PM	2:37:55 PM	6
1	227	2:37:55 PM	2:38:06 PM	11
1	228	2:38:13 PM	2:39:19 PM	66
1	229	2:38:38 PM	2:39:30 PM	52
1	230	2:38:45 PM	2:39:34 PM	49
1	231	2:38:47 PM	2:39:37 PM	50
1	232	2:38:49 PM	2:39:47 PM	58
1	233	2:39:27 PM	2:39:52 PM	25
1	234	2:39:44 PM	2:39:54 PM	10
1	235	2:39:44 PM	2:39:57 PM	13
1	236	2:39:50 PM	2:40:12 PM	22
1	237	2:39:58 PM	2:41:12 PM	74
1	238	2:41:15 PM	2:41:18 PM	3
1	239	2:41:28 PM	2:41:37 PM	9
1	240	2:41:29 PM	2:41:38 PM	9
1	241	2:41:31 PM	2:41:46 PM	15
1	242	2:41:33 PM	2:41:50 PM	17

Burgess & Niple, Inc.

10006 N. Dale Mabry Hwy, Suite 201
Tampa, FL 33618
(813) 962-8689

SR 951 at Championship Dr
Section: 03030 MP: 7.578
Weather: Clear
County: Collier

File Name : 102_SR 951 at Championship Dr (WB) PM
Site Code : 00000102
Start Date : 2/18/2021
Page No : 5

L n.	No.	Joined Queue	Released From Queue	Delay
1	243	2:41:41 PM	2:41:53 PM	12
1	244	2:41:49 PM	2:43:10 PM	81
1	245	2:41:57 PM	2:43:13 PM	76
1	246	2:42:36 PM	2:43:15 PM	39
1	247	2:43:17 PM	2:43:37 PM	20
1	248	2:43:19 PM	2:43:55 PM	36
1	249	2:43:21 PM	2:43:57 PM	36
1	250	2:43:26 PM	2:44:06 PM	40
1	251	2:43:52 PM	2:44:26 PM	34
1	252	2:44:04 PM	2:44:29 PM	25
1	253	2:44:05 PM	2:44:32 PM	27
1	254	2:44:23 PM	2:44:36 PM	13
1	255	2:44:48 PM	2:44:53 PM	5
1	256	2:45:07 PM	2:45:10 PM	3
1	257	2:45:11 PM	2:45:35 PM	24
1	258	2:45:14 PM	2:45:50 PM	36
1	259	2:45:18 PM	2:45:54 PM	36
1	260	2:45:21 PM	2:45:57 PM	36
1	261	2:45:25 PM	2:46:09 PM	44
1	262	2:45:58 PM	2:46:11 PM	13
1	263	2:46:05 PM	2:46:16 PM	11
1	264	2:46:26 PM	2:46:41 PM	15
1	265	2:46:34 PM	2:46:45 PM	11
1	266	2:46:56 PM	2:46:59 PM	3
1	267	2:47:02 PM	2:47:05 PM	3
1	268	2:47:06 PM	2:47:11 PM	5
1	269	2:47:08 PM	2:47:23 PM	15
1	270	2:47:14 PM	2:48:35 PM	81
1	271	2:47:25 PM	2:48:39 PM	74
1	272	2:47:34 PM	2:48:42 PM	68
1	273	2:48:18 PM	2:48:48 PM	30
1	274	2:48:43 PM	2:48:49 PM	6
1	275	2:48:46 PM	2:48:53 PM	7
1	276	2:48:51 PM	2:48:57 PM	6
1	277	2:48:58 PM	2:49:01 PM	3
1	278	2:48:59 PM	2:49:03 PM	4
1	279	2:49:32 PM	2:49:57 PM	25
1	280	2:50:12 PM	2:50:18 PM	6
1	281	2:50:16 PM	2:50:20 PM	4
1	282	2:51:19 PM	2:52:02 PM	43
1	283	2:51:49 PM	2:52:08 PM	19
1	284	2:52:03 PM	2:52:17 PM	14
1	285	2:52:04 PM	2:52:24 PM	20
1	286	2:52:13 PM	2:52:28 PM	15
1	287	2:52:29 PM	2:53:09 PM	40
1	288	2:52:31 PM	2:53:15 PM	44
1	289	2:52:32 PM	2:53:24 PM	52
1	290	2:52:34 PM	2:53:33 PM	59
1	291	2:53:16 PM	2:53:34 PM	18
1	292	2:53:24 PM	2:53:46 PM	22
1	293	2:53:29 PM	2:53:54 PM	25
1	294	2:53:30 PM	2:54:01 PM	31
1	295	2:53:37 PM	2:54:05 PM	28
1	296	2:53:45 PM	2:54:08 PM	23
1	297	2:53:59 PM	2:54:16 PM	17
1	298	2:54:00 PM	2:54:20 PM	20
1	299	2:54:10 PM	2:54:24 PM	14
1	300	2:54:14 PM	2:54:25 PM	11
1	301	2:54:26 PM	2:54:28 PM	2
1	302	2:54:27 PM	2:54:38 PM	11
1	303	2:54:32 PM	2:55:16 PM	44

Burgess & Niple, Inc.

10006 N. Dale Mabry Hwy, Suite 201
Tampa, FL 33618
(813) 962-8689

SR 951 at Championship Dr
Section: 03030 MP: 7.578
Weather: Clear
County: Collier

File Name : 102_SR 951 at Championship Dr (WB) PM
Site Code : 00000102
Start Date : 2/18/2021
Page No : 6

L n.	No.	Joined Queue	Released From Queue	Delay	
1	304	2:54:41 PM	2:55:19 PM	38	
1	305	2:55:15 PM	2:55:23 PM	8	
1	306	2:55:46 PM	2:55:58 PM	12	
1	307	2:55:47 PM	2:56:07 PM	20	
1	308	2:55:50 PM	2:56:09 PM	19	
1	309	2:56:03 PM	2:56:13 PM	10	
1	310	2:56:06 PM	2:56:16 PM	10	
1	311	2:56:20 PM	2:56:23 PM	3	
1	312	2:57:05 PM	2:57:07 PM	2	
1	313	2:57:12 PM	2:57:20 PM	8	
1	314	2:57:32 PM	2:57:56 PM	24	
1	315	2:57:53 PM	2:58:04 PM	11	
1	316	2:57:58 PM	2:58:16 PM	18	
1	317	2:57:59 PM	2:58:34 PM	35	
1	318	2:58:11 PM	2:58:35 PM	24	
1	319	2:58:20 PM	2:58:44 PM	24	
1	320	2:58:25 PM	2:58:56 PM	31	
1	321	2:58:38 PM	2:59:00 PM	22	
1	322	2:58:55 PM	2:59:07 PM	12	
1	323	2:59:02 PM	2:59:44 PM	42	
1	324	2:59:04 PM	2:59:46 PM	42	
1	325	2:59:13 PM	2:59:49 PM	36	
1	326	2:59:15 PM	2:59:54 PM	39	
1	327	2:59:18 PM	2:59:58 PM	40	
1	328	2:59:36 PM	3:00:00 PM	24	

Summary Information:

2:00:00 PM - 3:01:00 PM	Lane 1
Total Vehicle Count:	328
Delayed Vehicle Count:	328
Through Vehicle Count:	0
Average Stopped Time:	28.25
Maximum Stopped Time:	91
Min. Secs. for Delay:	0
Average Queue:	2.57
Queue Density:	3.01
Maximum Queue:	8
Delay in Vehicle Hour:	2.57
Total Delay:	9265

APPENDIX D

Signal Warrant Analysis

TRAFFIC SIGNAL WARRANT SUMMARY

City: Naples
 County: 03 - Collier
 District: One

Engineer: Danny Hendrickson
 Date: May 5, 2021

Major Street: SR 951 (Collier Blvd) Lanes: 2 Major Approach Speed: 55
 Minor Street: Championship Dr Lanes: 1 Minor Approach Speed: 30

MUTCD Electronic Reference to Chapter 4: <http://mutcd.fhwa.dot.gov/pdfs/2009r1r2/part4.pdf>

Volume Level Criteria

- 1. Is the posted speed or 85th-percentile of major street > 40 mph (70 km/h)? Yes No
 - 2. Is the intersection in a built-up area of an isolated community with a population < 10,000? Yes No
- "70%" volume level may be used if Question 1 or 2 above is answered "Yes" 70% 100%

WARRANT 1 - EIGHT-HOUR VEHICULAR VOLUME

Warrant 1 is satisfied if Condition A or Condition B is "100%" satisfied for eight hours Yes No
 Warrant 1 is also satisfied if both Condition A and Condition B are "80%" satisfied (should only be applied after an adequate trial of other alternatives that could cause less delay and inconvenience to traffic has failed to solve the traffic problems). Yes No

Condition A - Minimum Vehicular Volume

Condition A is intended for application at locations where a large volume of intersecting traffic is the principal reason to consider installing a traffic control signal.

100% Satisfied: Yes No
 80% Satisfied: Yes No
 70% Satisfied: Yes No

Number of Lanes for moving traffic on each approach		Vehicles per hour on major-street (total of both approaches)			Vehicles per hour on minor-street (one direction only)		
Major	Minor	100% ^a	80% ^b	70% ^c	100% ^a	80% ^b	70% ^c
1	1	500	400	350	150	120	105
2 or more	1	600	480	420	150	120	105
2 or more	2 or more	600	480	420	200	160	140
1	2 or more	500	400	350	200	160	140

^a Basic Minimum hourly volume
^b Used for combination of Conditions A and B after adequate trial of other remedial measures
^c May be used when the major-street speed exceeds 40 mph or in an isolated community with a population of less than 10,000

Record 8 highest hours and the corresponding major-street and minor-street volumes in the Instructions Sheet.

Street	Eight Highest Hours							
	9:00 AM	10:00 AM	11:00 AM	12:00 PM	1:00 PM	2:00 PM	3:00 PM	4:00 PM
Major	2,801	3,021	3,175	3,166	3,156	3,384	3,548	3,519
Minor	186	208	194	190	172	178	161	152

Existing Volumes

State of Florida Department of Transportation
TRAFFIC SIGNAL WARRANT SUMMARY

Condition B - Interruption of Continuous Traffic

Condition B is intended for application where Condition A is not satisfied and the traffic volume on a major street is so heavy that traffic on the minor intersecting street suffers excessive delay or conflict in entering or crossing the major street.

Applicable: Yes No

100% Satisfied: Yes No

80% Satisfied: Yes No

70% Satisfied: Yes No

Number of Lanes for moving traffic on each approach		Vehicles per hour on major-street (total of both approaches)			Vehicles per hour on minor-street (one direction only)		
Major	Minor	100% ^a	80% ^b	70% ^c	100% ^a	80% ^b	70% ^c
1	1	750	600	525	75	60	53
2 or more	1	900	720	630	75	60	53
2 or more	2 or more	900	720	630	100	80	70
1	2 or more	750	600	525	100	80	70

^a Basic Minimum hourly volume

^b Used for combination of Conditions A and B after adequate trial of other remedial measures

^c May be used when the major-street speed exceeds 40 mph or in an isolated community with a population of less than 10,000

Record 8 highest hours and the corresponding major-street and minor-street volumes in the Instructions Sheet.

Eight Highest Hours								
Street	9:00 AM	10:00 AM	11:00 AM	12:00 PM	1:00 PM	2:00 PM	3:00 PM	4:00 PM
Major	2,801	3,021	3,175	3,166	3,156	3,384	3,548	3,519
Minor	186	208	194	190	172	178	161	152

Existing Volumes

TRAFFIC SIGNAL WARRANT SUMMARY

City: Naples
County: 03 - Collier
District: One

Engineer: Danny Hendrickson
Date: May 5, 2021

Major Street: SR 951 (Collier Blvd) Lanes: 2 Major Approach Speed: 55
Minor Street: Championship Dr Lanes: 1 Minor Approach Speed: 30

MUTCD Electronic Reference to Chapter 4: <http://mutcd.fhwa.dot.gov/pdfs/2009r1r2/part4.pdf>

Volume Level Criteria

1. Is the posted speed or 85th-percentile of major street > 40 mph (70 km/h)? Yes No
 2. Is the intersection in a built-up area of an isolated community with a population < 10,000? Yes No
- "70%" volume level may be used if Question 1 or 2 above is answered "Yes" Yes No

WARRANT 2 - FOUR-HOUR VEHICULAR VOLUME

If all four points lie above the appropriate line, then the warrant is satisfied.

Applicable: Yes No
Satisfied: Yes No

Plot four volume combinations on the applicable figure below.

100% Volume Level

Four Highest Hours	Volumes	
	Major Street	Minor Street
9:00 AM	2801	186
10:00 AM	3021	208
11:00 AM	3175	194
12:00 PM	3166	190

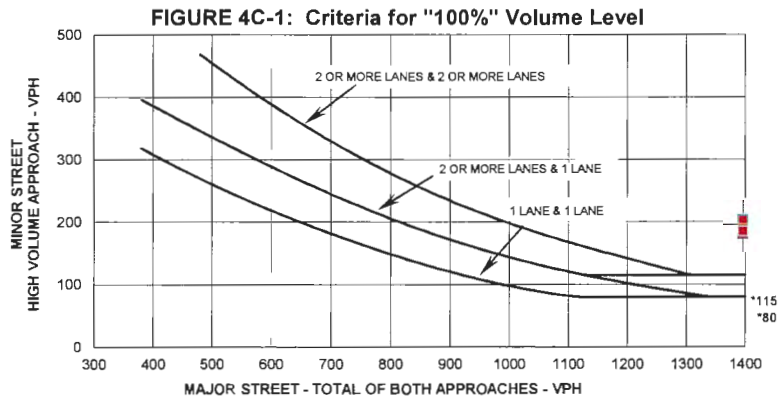

* Note: 115 vph applies as the lower threshold volume for a minor street approach with two or more lanes and 80 vph applies as the lower threshold volume threshold for a minor street approach with one lane.

70% Volume Level

Four Highest Hours	Volumes	
	Major Street	Minor Street
9:00 AM	2801	186
10:00 AM	3021	208
11:00 AM	3175	194
12:00 PM	3166	190

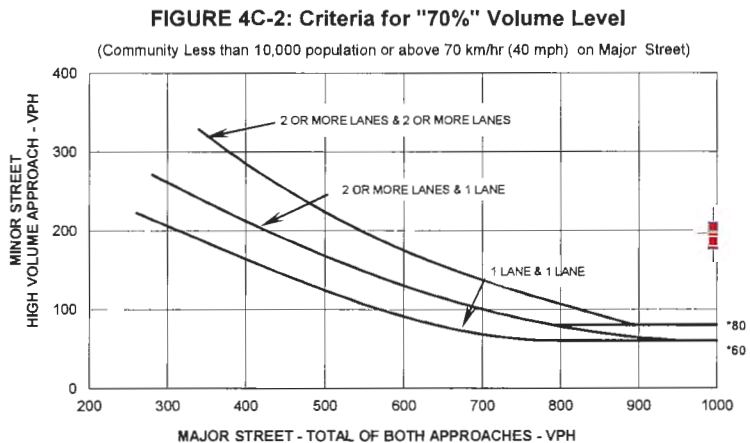

* Note: 80 vph applies as the lower threshold volume for a minor street approach with two or more lanes and 60 vph applies as the lower threshold volume threshold for a minor street approach with one lane.

State of Florida Department of Transportation
TRAFFIC SIGNAL WARRANT SUMMARY

Form 750-020-01
TRAFFIC ENGINEERING
10/15

City: Naples
County: 03 - Collier
District: One

Engineer: Danny Hendrickson
Date: May 5, 2021

Major Street: SR 951 (Collier Blvd)
Minor Street: Championship Dr

Lanes: 2 Major Approach Speed: 55
Lanes: 1 Minor Approach Speed: 30

MUTCD Electronic Reference to Chapter 4: <http://mutcd.fhwa.dot.gov/pdfs/2009r1r2/part4.pdf>

Volume Level Criteria

1. Is the posted speed or 85th-percentile of major street > 40 mph (70 km/h)? Yes No
 2. Is the intersection in a built-up area of an isolated community with a population < 10,000? Yes No
- "70%" volume level may be used if Question 1 or 2 above is answered "Yes" 70% 100%

WARRANT 3 - PEAK HOUR

If all three criteria are fulfilled **or** the plotted point lies above the appropriate line, then the warrant is satisfied.

Applicable: Yes No
Satisfied: Yes No

Unusual condition justifying use of warrant:

Record hour when criteria are fulfilled and the corresponding delay or volume in boxes provided.

Peak Hour 100% Volume		
Time	Major Vol.	Minor Vol.
10:00 AM	3021	208

Peak Hour 70% Volume		
Time	Major Vol.	Minor Vol.
10:00 AM	3021	208

Criteria

1. Delay on Minor Approach *(vehicle-hours)		
Approach Lanes	1	2
Delay Criteria*	4.0	5.0
Delay*		
Fulfilled?:	<input type="checkbox"/> Yes <input type="checkbox"/> No	

2. Volume on Minor Approach One-Direction *(vehicles per hour)		
Approach Lanes	1	2
Volume Criteria*	100	150
Volume*		
Fulfilled?:	<input type="checkbox"/> Yes <input type="checkbox"/> No	

3. Total Intersection Entering Volume *(vehicles per hour)		
No. of Approaches	3	4
Volume Criteria*	650	800
Volume*		
Fulfilled?:	<input type="checkbox"/> Yes <input type="checkbox"/> No	

Plot volume combination on the applicable figure below.

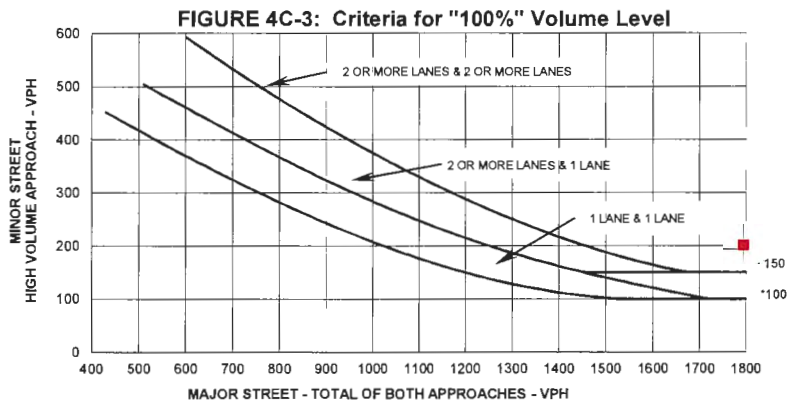

* Note: 150 vph applies as the lower threshold volume for a minor street approach with two or more lanes and 100 vph applies as the lower threshold volume threshold for a minor street approach with one lane.

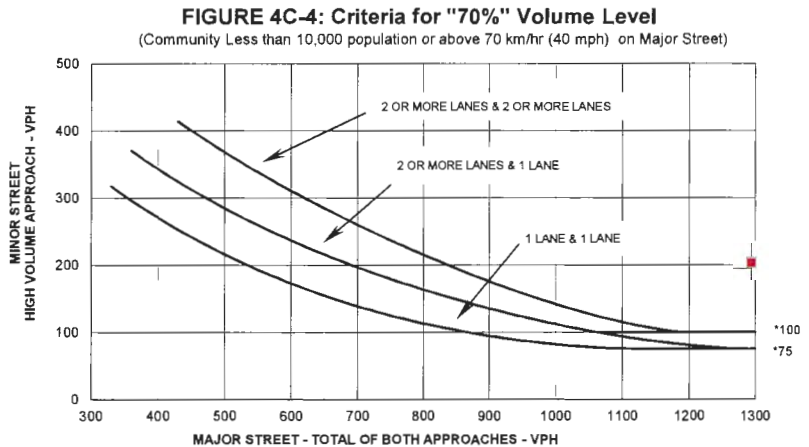

* Note: 100 vph applies as the lower threshold volume for a minor street approach with two or more lanes and 75 vph applies as the lower threshold volume threshold for a minor street approach with one lane.

State of Florida Department of Transportation
TRAFFIC SIGNAL WARRANT SUMMARY

Form 750-020-01
TRAFFIC ENGINEERING
10/15

City: Naples
County: 03 - Collier
District: One

Engineer: Danny Hendrickson
Date: May 5, 2021

Major Street: SR 951 (Collier Blvd) Lanes: 2 Major Approach Speed: 55
Minor Street: Championship Dr Lanes: 1 Minor Approach Speed: 30

MUTCD Electronic Reference to Chapter 4: <http://mutcd.fhwa.dot.gov/pdfs/2009r1r2/part4.pdf>

Volume Level Criteria

1. Is the posted speed or 85th-percentile of major street > 40 mph (70 km/h)? Yes No
 2. Is the intersection in a built-up area of an isolated community with a population < 10,000? Yes No
- "70%" volume level **may** be used if Question 1 **or** 2 above is answered "Yes" 70% 100%

WARRANT 4 - PEDESTRIAN VOLUME

For each of any 4 hours of an average day, the plotted points lie above the appropriate line, then the warrant is satisfied. Applicable: Yes No
Satisfied: Yes No

Plot four volume combinations on the applicable figure below.

Figure 4C-5. Criteria for "100%" Volume Level

Four Highest Hours	Volumes	
	Major Street	Pedestrian Total

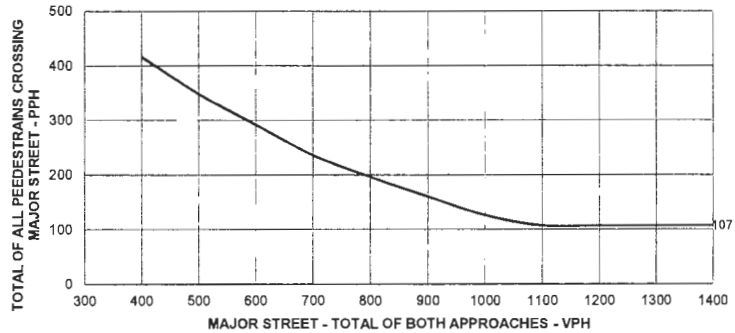

* Note: 107 pph applies as the lower threshold volume

Figure 4C-6 Criteria for "70%" Volume Level

Four Highest Hours	Volumes	
	Major Street	Pedestrian Total
9:00 AM	2801	
10:00 AM	3021	1
11:00 AM	3175	
12:00 PM	3166	

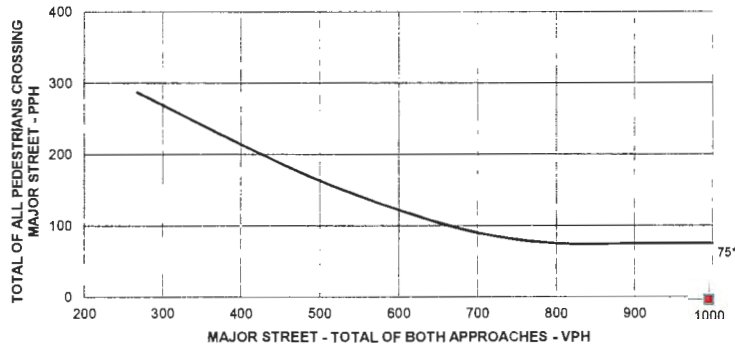

* Note: 75 pph applies as the lower threshold volume

WARRANT 4 - PEDESTRIAN VOLUME

For 1 hour (any four consecutive 15-minute periods) of an average day, the plotted point falls above the appropriate line, then the warrant is satisfied.

Applicable: Yes No
 Satisfied: Yes No

Plot one volume combination on the applicable figure below.

100% Volume Level

Peak Hour	Volumes	
	Major Street	Pedestrian Total

Figure 4C-7. Criteria for "100%" Volume Level - Peak Hour

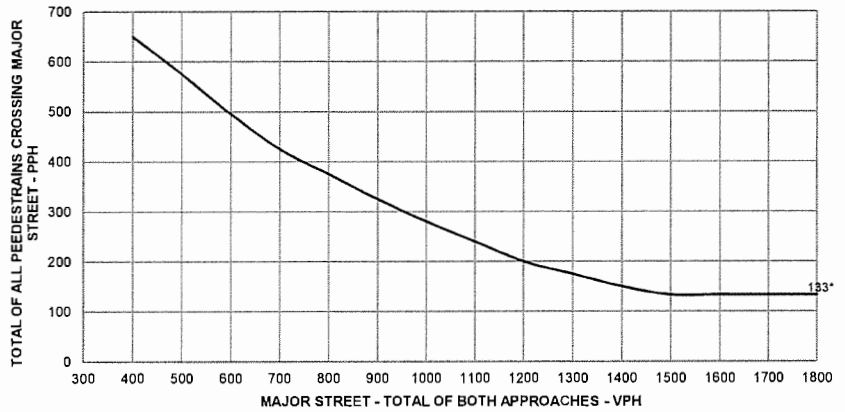

* Note: 133 pph applies as the lower threshold volume

70% Volume Level

Peak Hour	Volumes	
	Major Street	Pedestrian Total
10:00 AM	3021	1

Figure 4C-8 Criteria for "70%" Volume Level - Peak Hour

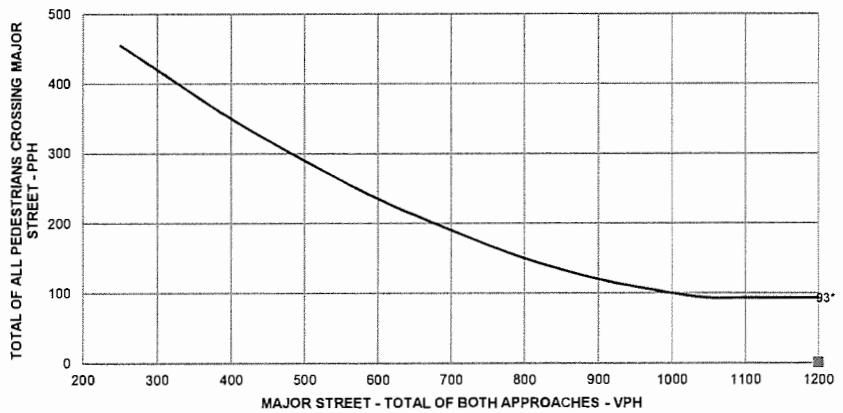

* Note: 93 pph applies as the lower threshold volume

TRAFFIC SIGNAL WARRANT SUMMARY

City: Naples
 County: 03 - Collier
 District: One

Engineer: Danny Hendrickson
 Date: May 5, 2021

Major Street: SR 951 (Collier Blvd) Lanes: 2 Major Approach Speed: 55
 Minor Street: Championship Dr Lanes: 1 Minor Approach Speed: 30

MUTCD Electronic Reference to Chapter 4: <http://mutcd.fhwa.dot.gov/pdfs/2009r1r2/part4.pdf>

WARRANT 5 - SCHOOL CROSSING

Record hours where criteria are fulfilled and the corresponding volume or gap frequency in the boxes provided. The warrant is satisfied if all three of the criteria are fulfilled.

Applicable: Yes No

Satisfied: Yes No

Criteria				Fulfilled?	
				Yes	No
1. There are a minimum of 20 students crossing the major street during the highest crossing hour.	Students:	Hour:			
2. when the children are using the established school crossing than the number of minutes in the same period.	Minutes:		Gaps:		
3. The nearest traffic signal along the major street is located more than 300 ft. (90 m) away, or the nearest signal is within 300 ft. (90 m) but the proposed traffic signal will not restrict the progressive movement of traffic.					

TRAFFIC SIGNAL WARRANT SUMMARY

City: Naples
County: 03 – Collier
District: One

Engineer: Danny Hendrickson
Date: May 5, 2021

Major Street: SR 951 (Collier Blvd)
Minor Street: Championship Dr

Lanes: 2
Lanes: 1

Major Approach Speed: 55
Minor Approach Speed: 30

MUTCD Electronic Reference to Chapter 4: <http://mutcd.fhwa.dot.gov/pdfs/2009r1r2/part4.pdf>

WARRANT 6 - COORDINATED SIGNAL SYSTEM

Indicate if the criteria are fulfilled in the boxes provided. The warrant is satisfied if either criterion is fulfilled. This warrant should not be applied when the resulting signal spacing would be less than 300 m (1,000 ft.).

Applicable: Yes No
Satisfied: Yes No

Criteria	Fulfilled?	
	Yes	No
1. On a one-way street or a street that has traffic predominately in one direction, the adjacent signals are so far apart that they do not provide the necessary degree of vehicle platooning.		No
2. On a two-way street, adjacent signals do not provide the necessary degree of platooning, and the proposed and adjacent signals will collectively provide a progressive operation.		No

State of Florida Department of Transportation
TRAFFIC SIGNAL WARRANT SUMMARY

Form 750-020-01
 TRAFFIC ENGINEERING
 10/15

City: Naples
 County: 03 – Collier
 District: One

Engineer: Danny Hendrickson
 Date: May 5, 2021

Major Street: SR 951 (Collier Blvd)
 Minor Street: Championship Dr

Lanes: 2 Major Approach Speed: 55
 Lanes: 1 Minor Approach Speed: 30

MUTCD Electronic Reference to Chapter 4: <http://mutcd.fhwa.dot.gov/pdfs/2009r1r2/part4.pdf>

WARRANT 7 - CRASH EXPERIENCE

Record hours where criteria are fulfilled, the corresponding volume, and other information in the boxes provided. The warrant is satisfied if all three of the criteria are fulfilled.

Applicable: Yes No

Satisfied: Yes No

Criteria	Hour	Volume		Met?		Fulfilled?	
		Major	Minor	Yes	No	Yes	No
1. One of the warrants to the right is met.	Warrant 1, Condition A (80% satisfied)				Yes		Yes
	Warrant 1, Condition B (80% satisfied)				Yes		
	Warrant 4, Pedestrian Volume at 80% of volume requirements: # ped/hr for four (4) hours or # ped/hr for one (1) hour.					No	
2. Adequate trial of other remedial measure has failed to reduce crash frequency.	Measure tried:						No
3. Five or more reported crashes, of types susceptible to correction by signal, have occurred within a 12-month period.	Observed Crash Types:	Angle	Number of crashes per 12 months:		1		No

State of Florida Department of Transportation
TRAFFIC SIGNAL WARRANT SUMMARY

Form 750-020-01
 TRAFFIC ENGINEERING
 10/15

City: Naples
 County: 03 – Collier
 District: One

Engineer: Danny Hendrickson
 Date: May 5, 2021

Major Street: SR 951 (Collier Blvd) Lanes: 2 Major Approach Speed: 55
 Minor Street: Championship Dr Lanes: 1 Minor Approach Speed: 30

MUTCD Electronic Reference to Chapter 4: <http://mutcd.fhwa.dot.gov/pdfs/2009r1r2/part4.pdf>

WARRANT 8 - ROADWAY NETWORK

Record hours where criteria are fulfilled, and the corresponding volume or other information in the boxes provided. The warrant is satisfied if at least one of the criteria is fulfilled and if all intersecting routes have one or more of the Major Route characteristics listed.

Applicable: Yes No

Satisfied: Yes No

Criteria						Met?		Fulfilled?	
						Yes	No	Yes	No
1.	Both of the criteria to the right are met.	a. Total entering volume of at least 1,000 veh/hr during a typical weekday peak hour.	Entering Volume:						
		b. Five-year projected volumes that satisfy one or more of Warrants 1, 2, or 3.	Warrant:	1	2				
		Satisfied?:							
2.	Total entering volume at least 1,000 veh/hr for each of any 5 hrs of a non-normal business day (Sat. or Sun.)						← Hour		
							← Volume		

Characteristics of Major Routes						Met?		Fulfilled?	
						Yes	No	Yes	No
1.	Part of the street or highway system that serves as the principal roadway network for through traffic flow.	Major Street:							
		Minor Street:							
2.	Rural or suburban highway outside of, entering, or traversing a city.	Major Street:							
		Minor Street:							
3.	Appears as a major route on an official plan.	Major Street:							
		Minor Street:							

TRAFFIC SIGNAL WARRANT SUMMARY

City: Naples
County: 03 - Collier
District: One

Engineer: Danny Hendrickson
Date: May 5, 2021

Major Street: SR 951 (Collier Blvd)
Minor Street: Championship Dr

Lanes: 2 Major Approach Speed: 55
Lanes: 1 Minor Approach Speed: 30

MUTCD Electronic Reference to Chapter 4: <http://mutcd.fhwa.dot.gov/pdfs/2009r1r2/part4.pdf>

Approach Lane Criteria

1. How many approach lanes are there at the track crossing?

1 2 or

If there is 1 lane, use Figure 4C-9 and if there are 2 or more, use Figure 4C-10.

Fig 4C-9 Fig 4C-10

WARRANT 9 - INTERSECTION NEAR A GRADE CROSSING

This signal warrant should be applied only after adequate consideration has been given to other alternatives or after a trial of an alternative has failed to alleviate the safety concerns associated with the grade crossing.

Indicate if both criteria are fulfilled in the boxes provided. The warrant is satisfied if both criteria are met.

Applicable: Yes No

Satisfied: Yes No

Criteria	Fulfilled?	
	Yes	No
1. A grade crossing exists on an approach controlled by a STOP or YIELD sign and the center of the track nearest to the intersection is within 140 feet of the stop line or yield line on the approach; and	<input type="checkbox"/>	<input type="checkbox"/>
2. During the highest traffic volume hour during which the rail uses the crossing, the plotted point falls above the applicable curve for the existing combination of approach lanes over the track and the distance D (clear storage distance).	<input type="checkbox"/>	<input type="checkbox"/>

Use the following tables (4C-2, 4C-3, and 4C-4 to appropriately adjust the minor-street approach volume).

Inputs

Occurrences of Rail traffic per day
% of High Occupancy Buses on Minor-Street Approach
Enter D (feet)
% of Tractor-Trailer Trucks on Minor-Street Approach

	1.00
	0.50

Adjustment Factors from Tables

Table 4C-2. Adjustment Factor for Daily Frequency of Rail Traffic

Rail Traffic per Day	Adjustment Factor
1	0.67
2	0.91
3 to 5	1.00
6 to 8	1.18
9 to 11	1.25
12 or more	1.33

Table 4C-3. Adjustment Factor for Percentage of High-Occupancy Buses

% of High-Occupancy Buses* on Minor Street Approach	Adjustment Factor
0%	1.00
2%	1.09
4%	1.19
6% or more	1.32

* A high-occupancy bus is defined as a bus occupied by at least 20 people

Table 4C-4. Adjustment Factor for Percentage of Tractor-Trailer Trucks

% of Tractor-Trailer Trucks on Minor-Street Approach	Adjustment Factor	
	D less than 70 feet	D of 70 feet or more
0% to 2.5%	0.50	0.50
2.6% to 7.5%	0.75	0.75
7.6% to 12.5%	1.00	1.00
12.6% to 17.5%	2.30	1.15
17.6% to 22.5%	2.70	1.35
22.6% to 27.5%	3.28	1.64
More than 27.5%	4.18	2.09

Input the major and minor street volumes before adjustment factors are applied

1 Approach Lane		

D (ft) Major Vol. Minor Vol.

After adjustment factors are applied

1 Approach Lane w/Factors		

D (ft) Major Vol. Minor Vol.

Input D and the major and minor street volumes before adjustment factors are applied

2 or more Approach Lanes		

D (ft) Major Vol. Minor Vol.

After adjustment factors are applied

2+ Approach Lane w/Factors		

D (ft) Major Vol. Minor Vol.

FIGURE 4C-9: Criteria for 1 Approach Lane at the Track Crossing

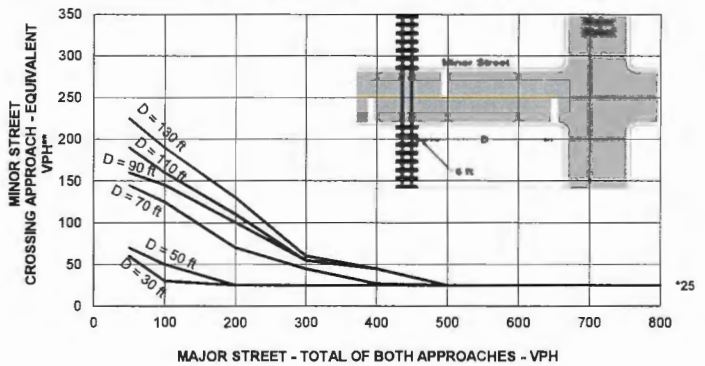

* Note: 25 vph applies as the lower threshold volume

**Note: VPH after applying the adjustment factors in Tables 4C-2, 4C, and/or 4C-4, if appropriate

FIGURE 4C-10: Criteria for 2+ Approach Lanes at Track Crossing

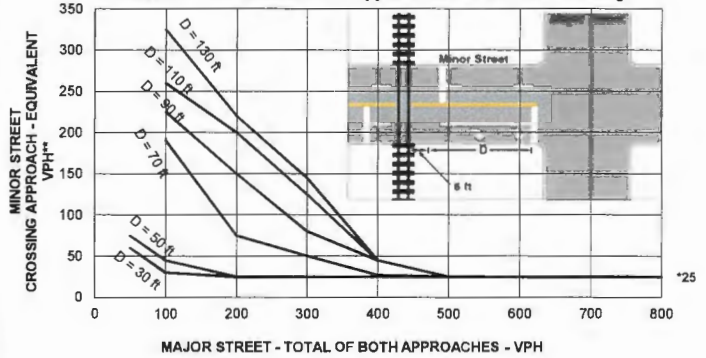

* Note: 25 vph applies as the lower threshold volume

**Note: VPH after applying the adjustment factors in Tables 4C-2, 4C, and/or 4C-4, if appropriate

TRAFFIC SIGNAL WARRANT SUMMARY

City: Naples
 County: 03 - Collier
 District: One

Engineer: Danny Hendrickson
 Date: May 5, 2021

Major Street: SR 951 (Collier Blvd)
 Minor Street: Championship Dr

Lanes: 2 Major Approach Speed: 55
 Lanes: 1 Minor Approach Speed: 30

MUTCD Electronic Reference to Chapter 4: <http://mutcd.fhwa.dot.gov/pdfs/2009r1r2/part4.pdf>

CONCLUSIONS

Remarks: The intersection meets Warrant 1 (8-Hour Volume) and Warrant 2 (4-Hour Volume) as outlined in the MUTCD.

WARRANTS SATISFIED:

<input checked="" type="checkbox"/> Warrant 1	<input type="checkbox"/> Not Applicable
<input checked="" type="checkbox"/> Warrant 2	<input type="checkbox"/> Not Applicable
<input type="checkbox"/> Warrant 3	<input checked="" type="checkbox"/> Not Applicable
<input type="checkbox"/> Warrant 4	<input type="checkbox"/> Not Applicable
<input type="checkbox"/> Warrant 5	<input checked="" type="checkbox"/> Not Applicable
<input type="checkbox"/> Warrant 6	<input type="checkbox"/> Not Applicable
<input type="checkbox"/> Warrant 7	<input type="checkbox"/> Not Applicable
<input type="checkbox"/> Warrant 8	<input checked="" type="checkbox"/> Not Applicable
<input type="checkbox"/> Warrant 9	<input checked="" type="checkbox"/> Not Applicable

FIDDLER'S CREEK
COMMUNITY DEVELOPMENT DISTRICT
#1

12

Fiddlers Creek Landscape Advisory Committee

Meeting Agenda - March 7, 2022

Landscape Advisory Team and Areas of Coverage:

Shannon Benedetti

Entrances/Security Buildings

Fiddlers Creek Parkway

Veneta

Club Center

Marsh Entrance

Club Center

Cherry Oaks Trail

Championship

Monuments and curbs (report to Todd Lux)

Joan Smith

Aviamar

Aviamar side of Sandpiper

Linda Fox

Oyster Harbor

Oyster side of Sandpiper

Judy Tibbs and Margi Cardillo

Fiddlers Creek Clubhouse Grounds

Advisory Charter:

Make observations of landscape, monuments, road gutters and report.

Club: Ron Albeit, General Manager, Sean Gradomski, Club Manager, Todd Lux Facilities

CDD#1&2 Boards and to Cleo Adams, Wrathall, Hunt & Associates

ADVISORY TEAM REPORTS AND DISCUSSION TOPICS:

Fiddlers Creek Main Entrance Area

Current annuals at entrance - from ClubCare - Red and White Big Begonia

Landcare Update:

Subsequent to February 23, 2022 CDD meetings Cleo Adams rode through Fiddlers Creek with Landcare to make observations and provide directions for landscape resolution.

Landcare crews were on site February 17 and 18 addressing the issues.

Entrance to Fiddlers Creek Parkway - CDD#1

Examples of dead or sad bougainvillea shrubs in medians and in outer beds. I think that Landcare is providing nutrition and making observations to try to save the shrubs.



Front entrance side beds and medians still have bougainvillea shrubs needing attention.

The bougs in this area took a little longer to recover from cold, however, they have rebounded and starting to look much better. Shrubs have been fertilized and trimmed.

Parkway entrance to Security building - CDD#1

Area along the right side of the road needs attention. Shrubs are not thriving and some are dead. Landcare was on site the week of March 1, 2022 spraying the area with nutrition and bug prevention, trying to resurrect the shrubs.



Bougainvillea have been fertilized and trimmed down to rail height. Slow to recover but healthy and pushing out new growth. Plants have been in for two years when new guard rail was installed. Havent grown like the sections before and after middle section. The exit side is beautiful, same treatment on both sides but middle entrance side hasnt been growing the same.

Bougainvillea have been fertilized and trimmed. Plants have been slow to recover but are pushing out growth and flowers. Some replacement plants have been added.

Fiddlers Creek Parkway, CDD#1 -



I broke some branches and some are still green inside, others are not. Landcare has been driving through to observe and keep these on a watch to see if they will resurrect.

Photo examples below. Runaway to Club, Isla, Majorca. Reported in November 2021. NO CHANGE. Many of the areas are without shrubs and other shrubs have aged out and will need to be replaced at some time in the future.



New Bougainvillea shrubs have been installed along the border at Cherry Oaks.

Yes - plants have been installed

Club Center - CDD#1. (No change from last report)

Corner of FC Pkwy and Club Center (next to Marriott Golf) Dead and dying Bougainvillea, dead and dying shrubs along the walkway, a variety of dead and dying shrubs along the Marriott Golf course on Club Center Blvd.



Note that Landcare cleaned up the median across from the FC Club entrance on Club Center.

All bougs have been fertilized and trimmed up and are looking better. There are a few thick trunked older bougs that should be replaced but it is a difficult area for them to thrive.

Durantha have been removed but are not doing well in this area. Recommend new plant palate for this area.

Fiddlers Creek Parkway between Sandpiper and Dead End.

Dead Bougainvillea in FC Pkwy median - Beds were cleaned up but the unattractive shrubs remain. Landcare may be waiting to see if they can be saved.



Median between Sandpiper and dead end. Gold Mound shrubs have 90% dead branches, but a few branches with leaves. Landcare is trying to determine what is causing the decline and trying to save them.

Shrubs have been removed and the newer plants recently planted have been moved to make a complete bed around island. The one island over the years have not thrived in this area and recommend new plant material.

S

FIDDLER'S CREEK
COMMUNITY DEVELOPMENT DISTRICT
#1

13

**FIDDLER'S CREEK
COMMUNITY DEVELOPMENT DISTRICT #1
FINANCIAL STATEMENTS
UNAUDITED
FEBRUARY 28, 2022**

**FIDDLER'S CREEK
COMMUNITY DEVELOPMENT DISTRICT #1
BALANCE SHEET
GOVERNMENTAL FUNDS
FEBRUARY 28, 2022**

	General 001	Debt Service Series 2013 Refunded 1999	Debt Service Series 2014-1 Refunded 2002B	Debt Service Series 2014-2A Refunded 2002A	Debt Service Series 2014-2B Refunded 2002A	Debt Service Series 2014-3 Refunded 2005	Debt Service Series 2014-4 Refunded 2005	Total Governmental Funds
ASSETS								
Operating accounts								
SunTrust	\$ 2,223,975	\$ -	\$ -	\$ -	\$ -	\$ -	\$ -	\$ 2,223,975
Assessment account-Iberia	300,912	-	-	-	-	-	-	300,912
Centennial Bank - MMA	77,729	-	-	-	-	-	-	77,729
Finemark - MMA	249,013	-	-	-	-	-	-	249,013
Finemark - ICS	725,169	-	-	-	-	-	-	725,169
Investments								
Revenue	-	-	514,042	-	423,256	-	-	937,298
Reserve - series B	-	-	-	-	104,003	-	-	104,003
Prepayment	-	-	-	978	250,205	-	-	251,183
Prepayment - 2002B exchange	-	-	41,197	-	-	-	-	41,197
Due from Fiddler's Creek CDD #2	30,978	-	-	-	-	-	-	30,978
Prepaid expense	1,262	-	-	-	-	-	-	1,262
Deposits	5,125	-	-	-	-	-	-	5,125
Total Assets	<u>\$ 3,614,163</u>	<u>\$ -</u>	<u>\$ 555,239</u>	<u>\$ 978</u>	<u>\$ 777,464</u>	<u>\$ -</u>	<u>\$ -</u>	<u>\$ 4,947,844</u>
LIABILITIES & FUND BALANCES								
Liabilities:	-	-	-	-	-	-	-	-
Total liabilities	-	-	-	-	-	-	-	-
Fund balances:								
Restricted for								
Debt service	-	-	555,239	978	777,464	-	-	1,333,681
Unassigned	3,614,163	-	-	-	-	-	-	3,614,163
Total fund balances	<u>3,614,163</u>	<u>-</u>	<u>555,239</u>	<u>978</u>	<u>777,464</u>	<u>-</u>	<u>-</u>	<u>4,947,844</u>
Total liabilities and fund balance	<u>\$ 3,614,163</u>	<u>\$ -</u>	<u>\$ 555,239</u>	<u>\$ 978</u>	<u>\$ 777,464</u>	<u>\$ -</u>	<u>\$ -</u>	<u>\$ 4,947,844</u>

**FIDDLER'S CREEK
COMMUNITY DEVELOPMENT DISTRICT #1
STATEMENT OF REVENUES, EXPENDITURES,
AND CHANGES IN FUND BALANCES
GENERAL FUND 001
FOR THE PERIOD ENDED FEBRUARY 28, 2022**

	Current Month	Year To Date	Budget	% of Budget
REVENUES				
Assessment levy	\$ 50,185	\$ 2,150,666	\$ 2,450,351	88%
Assessment levy: off-roll	31,418	157,090	377,017	42%
Interest	43	235	-	N/A
Total revenues	<u>81,646</u>	<u>2,307,991</u>	<u>2,827,368</u>	82%
EXPENDITURES				
Administrative				
Supervisors	-	2,799	12,918	22%
Management	5,044	25,219	60,525	42%
Assessment roll preparation	-	-	25,490	0%
Accounting services	1,647	8,235	19,764	42%
Audit	-	-	15,400	0%
Legal	4,262	10,180	25,000	41%
Engineering	-	11,003	50,000	22%
Telephone	68	338	810	42%
Postage	438	693	2,300	30%
Insurance	-	30,343	30,000	101%
Printing and binding	55	275	659	42%
Legal advertising	3,243	4,649	2,000	232%
Office supplies	325	325	750	43%
Annual district filing fee	-	175	175	100%
Trustee	-	-	15,500	0%
Arbitrage rebate calculation	-	-	4,000	0%
Contingencies	61	693	4,000	17%
ADA website compicance	-	-	920	0%
Dissemination agent	986	4,928	11,828	42%
Total administrative	<u>16,129</u>	<u>99,855</u>	<u>282,039</u>	35%
Field management				
Field management services	2,186	10,931	26,237	42%
Total field management	<u>2,186</u>	<u>10,931</u>	<u>26,237</u>	42%
Water management maintenance				
Other contractual	16,370	79,900	267,506	30%
Fountains	6,711	39,281	65,000	60%
Total water management maintenance	<u>23,081</u>	<u>119,181</u>	<u>332,506</u>	36%
Street lighting				
Contractual services	397	4,907	15,000	33%
Electricity	2,166	11,853	28,000	42%
Holiday lighting program	-	16,500	16,500	100%
Miscellaneous	-	-	1,500	0%
Total street lighting	<u>2,563</u>	<u>33,260</u>	<u>61,000</u>	55%

**FIDDLER'S CREEK
COMMUNITY DEVELOPMENT DISTRICT #1
STATEMENT OF REVENUES, EXPENDITURES,
AND CHANGES IN FUND BALANCES
GENERAL FUND 001
FOR THE PERIOD ENDED FEBRUARY 28, 2022**

	Current Month	Year To Date	Budget	% of Budget
Landscaping				
Other contractual - landscape maintenance	97,566	217,736	895,000	24%
Other contractual - flowers	-	18,980	52,000	37%
Other contractual - mosquito control	-	-	40,000	0%
Improvements and renovations	250	9,030	125,000	7%
Contingencies	-	-	15,000	0%
Total landscaping	<u>97,816</u>	<u>245,746</u>	<u>1,127,000</u>	22%
Roadway				
Roadway maintenance	-	9,633	85,000	11%
Capital outlay	-	-	400,000	0%
Total roadway	<u>-</u>	<u>9,633</u>	<u>485,000</u>	2%
Irrigation supply				
Electricity	50	228	750	30%
Repairs and maintenance	17,988	58,558	5,000	1171%
Other contractual-irrigation manager	-	-	50,000	0%
Supply system	6,476	40,866	368,500	11%
Total irrigation supply	<u>24,514</u>	<u>99,652</u>	<u>424,250</u>	23%
Other fees & charges				
Property appraiser	-	-	38,287	0%
Tax collector	1,018	22,035	51,049	43%
Total other fees & charges	<u>1,018</u>	<u>22,035</u>	<u>89,336</u>	25%
Total expenditures	<u>167,307</u>	<u>640,293</u>	<u>2,827,368</u>	23%
Excess/(deficiency) of revenues over/(under) expenditures	(85,661)	1,667,698	-	
OTHER FINANCING SOURCES/(USES)				
Transfers in	-	118,266	-	N/A
Total other financing sources/(uses)	<u>-</u>	<u>118,266</u>	<u>-</u>	N/A
Net change in fund balances	(85,661)	1,785,964	-	
Fund balances - beginning	3,699,824	1,828,199	1,810,790	
Fund balances - ending	<u>\$ 3,614,163</u>	<u>\$ 3,614,163</u>	<u>\$ 1,810,790</u>	

**FIDDLER'S CREEK
COMMUNITY DEVELOPMENT DISTRICT #1
STATEMENT OF REVENUES, EXPENDITURES,
AND CHANGES IN FUND BALANCES
DEBT SERVICE FUND SERIES 2013 (REFUNDED SERIES 1999)
FOR THE PERIOD ENDED FEBRUARY 28, 2022**

	Current Month	Year To Date
REVENUES	<u>\$ -</u>	<u>\$ -</u>
Total revenues	<u>-</u>	<u>-</u>
EXPENDITURES	<u>-</u>	<u>-</u>
Total expenditures	<u>-</u>	<u>-</u>
Excess/(deficiency) of revenues over/(under) expenditures	-	-
OTHER FINANCING SOURCES/(USES)		
Transfers out	-	(118,266)
Total other financing sources/(uses)	<u>-</u>	<u>(118,266)</u>
Net change in fund balances	-	(118,266)
Fund balances - beginning	-	118,266
Fund balances - ending	<u><u>\$ -</u></u>	<u><u>\$ -</u></u>

**FIDDLER'S CREEK
COMMUNITY DEVELOPMENT DISTRICT #1
STATEMENT OF REVENUES, EXPENDITURES,
AND CHANGES IN FUND BALANCES
DEBT SERVICE FUND SERIES 2014-1 (REFUNDED SERIES 2002B)
FOR THE PERIOD ENDED FEBRUARY 28, 2022**

	Current Month	Year To Date	Budget	% of Budget
REVENUES				
Assessment levy: on-roll - net	\$ 8,222	\$ 352,370	\$ 450,432	78%
Interest	1	7	-	N/A
Total revenues	<u>8,223</u>	<u>352,377</u>	<u>450,432</u>	78%
EXPENDITURES				
Debt service				
Principal	-	-	190,000	0%
Principal prepayment	-	155,000	-	N/A
Interest	-	110,472	220,944	50%
Total debt service	<u>-</u>	<u>265,472</u>	<u>410,944</u>	65%
Other fees & charges				
Property appraiser	-	-	7,038	0%
Tax collector	164	3,608	9,384	38%
Total other fees & charges	<u>164</u>	<u>3,608</u>	<u>16,422</u>	22%
Total expenditures	<u>164</u>	<u>269,080</u>	<u>427,366</u>	63%
Excess/(deficiency) of revenues over/(under) expenditures	8,059	83,297	23,066	
Fund balances - beginning	547,180	471,942	309,377	
Fund balances - ending	<u>\$ 555,239</u>	<u>\$ 555,239</u>	<u>\$ 332,443</u>	

**FIDDLER'S CREEK
COMMUNITY DEVELOPMENT DISTRICT #1
STATEMENT OF REVENUES, EXPENDITURES,
AND CHANGES IN FUND BALANCES
DEBT SERVICE FUND SERIES 2014-2A (REFUNDED SERIES 2002A)
FOR THE PERIOD ENDED FEBRUARY 28, 2022**

	Current Month	Year To Date	Budget	% of Budget
REVENUES				
Assessment levy: off-roll	\$ -	\$ -	\$ 361,094	0%
Total revenues	<u>-</u>	<u>-</u>	<u>361,094</u>	0%
EXPENDITURES				
Debt service				
Principal	-	-	160,000	0%
Interest	-	100,547	201,094	50%
Total debt service	<u>-</u>	<u>100,547</u>	<u>361,094</u>	28%
Excess/(deficiency) of revenues over/(under) expenditures	-	(100,547)	-	
Fund balances - beginning	978	101,525	331	
Fund balances - ending	<u>\$ 978</u>	<u>\$ 978</u>	<u>\$ 331</u>	

**FIDDLER'S CREEK
COMMUNITY DEVELOPMENT DISTRICT #1
STATEMENT OF REVENUES, EXPENDITURES,
AND CHANGES IN FUND BALANCES
DEBT SERVICE FUND SERIES 2014-2B (REFUNDED SERIES 2002A)
FOR THE PERIOD ENDED FEBRUARY 28, 2022**

	Current Month	Year To Date	Budget	% of Budget
REVENUES				
Assessment levy: on-roll - net	\$ 5,314	\$ 227,751	\$ 313,344	73%
Assessment prepayments	35,391	212,344	-	N/A
Interest	2	14	-	N/A
Total revenues	<u>40,707</u>	<u>440,109</u>	<u>313,344</u>	140%
EXPENDITURES				
Debt service				
Principal	-	-	135,000	0%
Principal prepayment	-	375,000	-	N/A
Interest	-	82,500	165,000	50%
Total debt service	<u>-</u>	<u>457,500</u>	<u>300,000</u>	153%
Other fees & charges				
Property appraiser	-	-	4,896	0%
Tax collector	106	2,332	6,528	36%
Total other fees & charges	<u>106</u>	<u>2,332</u>	<u>11,424</u>	20%
Total expenditures	<u>106</u>	<u>459,832</u>	<u>311,424</u>	148%
Excess/(deficiency) of revenues over/(under) expenditures	40,601	(19,723)	1,920	
Fund balances - beginning	736,863	797,187	386,561	
Fund balances - ending	<u>\$ 777,464</u>	<u>\$ 777,464</u>	<u>\$ 388,481</u>	

**FIDDLER'S CREEK
COMMUNITY DEVELOPMENT DISTRICT #1
STATEMENT OF REVENUES, EXPENDITURES,
AND CHANGES IN FUND BALANCES
DEBT SERVICE FUND SERIES 2014-3 (REFUNDED SERIES 2005)
FOR THE PERIOD ENDED FEBRUARY 28, 2022**

	<u>Current Month</u>	<u>Year To Date</u>	<u>Budget</u>	<u>% of Budget</u>
REVENUES				
Assessment levy: off-roll	\$ -	\$ -	\$ 595,000	0%
Total revenues	<u>-</u>	<u>-</u>	<u>595,000</u>	0%
EXPENDITURES				
Debt service				
Principal	-	-	220,000	0%
Interest	-	187,500	375,000	50%
Total debt service	<u>-</u>	<u>187,500</u>	<u>595,000</u>	32%
Excess/(deficiency) of revenues over/(under) expenditures	-	(187,500)	-	
Fund balances - beginning	-	187,500	1	
Fund balances - ending	<u>\$ -</u>	<u>\$ -</u>	<u>\$ 1</u>	

**FIDDLER'S CREEK
COMMUNITY DEVELOPMENT DISTRICT #1
STATEMENT OF REVENUES, EXPENDITURES,
AND CHANGES IN FUND BALANCES
DEBT SERVICE FUND SERIES 2014-4 (REFUNDED SERIES 2005)
FOR THE PERIOD ENDED FEBRUARY 28, 2022**

	Current Month	Year To Date	Budget	% of Budget
REVENUES				
Assessment levy: off-roll	\$ -	\$ -	\$ 626,000	0%
Total revenues	<u>-</u>	<u>-</u>	<u>626,000</u>	0%
EXPENDITURES				
Debt service				
Principal	-	-	230,000	0%
Interest	-	198,000	396,000	50%
Total debt service	<u>-</u>	<u>198,000</u>	<u>626,000</u>	32%
Excess/(deficiency) of revenues over/(under) expenditures	-	(198,000)	-	
Fund balances - beginning	-	198,000	2,672	
Fund balances - ending	<u>\$ -</u>	<u>\$ -</u>	<u>\$ 2,672</u>	

FIDDLER'S CREEK
COMMUNITY DEVELOPMENT DISTRICT
#1

14

DRAFT

MINUTES OF MEETING

FIDDLER’S CREEK COMMUNITY DEVELOPMENT DISTRICT #1

The Board of Supervisors of the Fiddler’s Creek Community Development District #1 held a Regular Meeting on February 23, 2022 at 8:00 a.m., at the Fiddler’s Creek Club and Spa, 3470 Club Center Boulevard, Naples, Florida 34114. Members of the public were able to participate in the meeting at 1-888-354-0094, Participant Passcode: 709 724 7992.

Present at the meeting were:

Robert Slater	Chair
Joseph Schmitt	Vice Chair
Joseph Badessa (via telephone)	Assistant Secretary
Torben Christensen	Assistant Secretary
Frank Weinberg	Assistant Secretary

Also present were:

Chuck Adams	District Manager
Cleo Adams	Assistant District Manager
Tony Pires	District Counsel
Terry Cole	District Engineer
Joe Parisi	Developer’s Counsel
Todd Lux	Fiddler’s Creek Director of Facilities
Ed Jasiocki	Fiddler’s Creek Director of Safety
Richard Renaud	Fiddler’s Creek Security
Christina Kennedy	SOLitude Lake Management (SOLitude)
Elliot Miller	CDD #2 Board Member
Shannon Benedetti	Resident/Landscape Advisory Committee
Joe Vacarro	Resident

FIRST ORDER OF BUSINESS

Call to Order/Roll Call

Mr. Slater called the meeting to order at 8:00 a.m. Supervisors Slater, Schmitt, Christensen and Weinberg were present. Supervisor Badessa was attending via telephone.

Audio commenced at approximately 8:05 a.m., just following the Call to Order and Roll Call.

On MOTION by Mr. Slater and seconded by Mr. Schmitt, with all in favor, authorizing Mr. Badessa’s attendance and full participation, via telephone, due to exceptional circumstances, was approved.

44 **SECOND ORDER OF BUSINESS**

Public Comments: Non-Agenda Items (3 minutes per speaker)

45
46
47
48

No members of the public spoke.

49 **THIRD ORDER OF BUSINESS**

Quality Control Lake Report - February, 2022: SOLitude Lake Management

50
51

Ms. Kennedy presented the Quality Control Lake Report and highlighted the following:

53 ➤ The Group C golf course lakes were treated this month; the more centrally located
54 Group B lakes were also reinspected and treated.

55 ➤ Affected lakes received weekly treatments, with the exception of an area on Lake 37A/B
56 where the presence of a large alligator made it unsafe to treat grasses in the area.

57 ➤ Illinois pondweed in the flow way system is responding to ongoing, targeted treatments.

58 A Board Member asked why Lake 34A is green. Ms. Kennedy stated a greenish color is
59 usually due to a plankton bloom and, since it affects the entire waterbody, spot treatments or
60 lake dyes can be utilized. Plankton is generally related to nutrients. She would inspect the lake.

61 Mr. Christensen asked if a new spray boat is being used. Ms. Kennedy stated the large
62 aluminum boat was used for submersed treatments so weighted hoses could be used.

63 Mrs. Adams asked to be informed about Lake 34A.

64

65 **FOURTH ORDER OF BUSINESS**

Health, Safety and Environment Report

66
67

A. Irrigation and Pressure Cleaning Efforts: Todd Lux

68 Mr. Lux gave a PowerPoint presentation and reported the following:

69 ➤ Residents, CDDs and HOAs experiencing issues are encouraged to send an email to
70 pressurewashing@Fiddlerscreek.com and/or IrrigationUsers@Fiddlerscreek.com.

71 ➤ Tree Canopy Trimming: Trimming is caught up and will resume in March, with the
72 fruited palms, which will be cut first in March and again in October. Juniper's previous manager
73 is no longer with the company. The trimming schedule would be monitored closely.

74 ➤ Pressure Washing: Over the past 30 days, crews have been working on Marsh Drive and
75 would proceed to Isla Del Sol. The old machine has been very problematic. The new pressure
76 washing machine should arrive soon and hopefully be operational within the next two weeks.

77 ➤ Current Month Projected Plan: Areas in red were completed and areas in yellow are
78 scheduled. Work is running behind but the new equipment should enable the crew to catch up.

79 Mr. Weinberg asked if the schedule includes Mahogany Bend. Mr. Lux replied
80 affirmatively; as the crew comes down Championship Drive, they will clean the surrounding
81 communities. Mr. Weinberg noted receiving complaints about sidewalk cleanliness. Mr. Lux
82 stated the schedule was planned to ensure every area is cleaned once a year. The cleaning
83 schedule and the need for a street sweeper in Mahogany Bend were discussed.

84 Ms. Benedetti stated, as a Landscape Advisory Committee member, she works with Mr.
85 Lux. They found ghosting in the streets, meaning stains are embedded. The street sweeper does
86 not totally clean the streets so she notifies Mr. Lux when an area needs to be addressed.

87 **B. Security and Safety Update: *Ed Jasiiecki***

88 Mr. Jasiiecki gave the monthly PowerPoint presentation and discussed the following:

89 ➤ The automated gatehouse number goes directly to voicemail and allows residents to
90 leave messages; messages are checked frequently but it is not answered by a live staff member.

91 ➤ The email address safety@fiddlerscreek.com is the preferred method of communication
92 for questions, concerns or visitor registration. Emails are monitored by all three gatehouses and
93 Supervisors 24 hours a day, 7 days a week and they are generally quick to respond.

94 Mr. Slater recommended e-blasting this information to residents. Although the
95 information is on the CDD website, an e-blast would be sent.

96 ➤ Community Patrol staff are not first responders. In an emergency, 911 should be called
97 first, followed by calling the Community Patrol, who will respond and assist. The Community
98 Patrol phone number is answered 24 hours a day, 7 days a week by the roving patrol officers.

99 ➤ Gate Access: In January, a total of 10,000 to 12,500 vehicles entered, with 2,000 to
100 4,000 vehicles entering weekly. The totals include all three gatehouses.

101 ➤ Occupancy Report: January residency was close to the December levels with about
102 8,862 residents currently on property.

103 ➤ Incidents Report: The numbers remain fairly consistent, month-to-month. Parking
104 warnings decreased noticeably in January.

105 ➤ The gate arms on Championship Drive were damaged. New gate arms are on backorder;
106 when they are replaced, the lighting strips will also be replaced.

107 A Board Member noted that the Traffic Hawk was deployed and asked about violations.
108 Mr. Jasiiecki stated there was one repeat violation that was sent to Ms. Lord for adjudication
109 through the fining committee or a letter. Mr. Renaud stated additional data would be compiled.

110 Resident Joe Vacarro asked about the permanent camera on Cherry Oaks Trail. Mr.
111 Jasiiecki stated the vendor is scheduled to address a connection issue.

112

113 FIFTH ORDER OF BUSINESS

Developer's Report

114

115 Regarding a missing fence between the Amaranda gatehouse and Sandpiper Drive, Mr.
116 Parisi stated the permit was resubmitted. It was found that Public Utility Easements (PUEs) exist
117 in the area and "No Objection" letters from each of the utilities are required; a County
118 employee found the letters and the permit was resubmitted. Work should begin shortly.

119 With regard to the gate behind Publix, Mr. Parisi stated the gate was fabricated and the
120 concrete will be delivered on Thursday. Permitting issues were resolved and construction
121 should begin on Thursday. A Board Member stated that numerous residents are using that area
122 as an entrance and exit. Mr. Parisi stated cones would be placed during construction.

123 The Amaranda gatehouse was discussed. Mr. Parisi stated a chain link fence would be
124 installed on the west side of the gatehouse to prevent pedestrian traffic in the gap between the
125 gatehouse arms and concrete fence. Chain link fence would be installed in other areas, such as
126 the wellness center. Mr. Parisi discussed permitting issues due to changes in the project scope;
127 the issues were resolved so the permit should be issued and work would begin soon.

128

129 SIXTH ORDER OF BUSINESS

Engineer's Report: *Hole Montes, Inc.*

130

131 Mr. Cole reported the following:

132 ➤ 20' to 30' of valley gutters were replaced on Mulberry Lane. Two additional areas might
133 need to be repaired due to blocked flow caused by tree roots.

134 Discussion ensued regarding the additional areas that need to be repaired and a
135 resident who emailed about a similar issue. Mr. Cole stated he would compile the addresses
136 and have the areas inspected. This item would be included on the next agenda. Mr. Pires stated
137 a rule would be considered at the March meeting.

138 ➤ The wall where the fencing shifted down was inspected with the contractor. The fence
139 was installed about four years ago and is likely not under warranty. It would probably cost

140 approximately \$3,000 for several days’ work straightening and repairing the settled areas. A
141 proposal was requested. The consensus was that this is an aesthetic matter.

142 ➤ The Mahogany Bend force main schedule was delayed due to equipment issues but
143 crews are making up time. Directional boring is underway and would last several weeks.

144 A resident thought the contractor did a good job informing the HOA of the progress.

145 ➤ There might be road closures in several months when milling is done. At the appropriate
146 time, an e-blast would be sent to the residents.

147 It was noted that the water line break on Fiddler’s Creek Parkway was the seventh one.
148 It was caught early and no sidewalk replacement was necessary but there could be issues in the
149 rainy season. The break involved a split along the whole length of the pipe.

150

151 **SEVENTH ORDER OF BUSINESS**

**Discussion: Preemptive Actions to Prevent
Further Damage Between Valley Gutters
and Sidewalks Caused by Trees in Affected
Areas**

152

153

154

155

156 Mr. Pires stated the rule change was advertised and would be presented in March. The
157 Foundation was asked to communicate the rule change to the HOA managers. Mr. Adams
158 would email the advertisement to The Foundation with a request for them to distribute it.

159

160 **EIGHTH ORDER OF BUSINESS**

**Consideration of Professional Services
Agreement with FL GIS Solutions, LLC**

161

162

163 Mr. Adams stated the person who has managed the GIS department for Passarella and
164 Associates (Passarella) started his own company, FL GIS Solutions, LLC (FLGIS). Passarella
165 charges \$140 per hour and the proposed FLGIS rate is \$110 per hour but he negotiated the rate
166 down to \$100 per hour, with an agreed rate lock for two years. Mr. Adams stated the annual
167 cost to maintain the GIS is typically \$3,000 to \$5,000 and all work product and records belong
168 to the CDD, as a governmental entity so the records can be requested from Passarella.

169 Regarding the added value of the GIS, Mr. Adams stated the GIS is invaluable. Mr. Cole
170 uses it and it includes links to the construction plans. Mrs. Adams stated Staff uses it daily. Mr.
171 Adams noted the GIS creates a living document that will remain with the CDD.

172 Mr. Slater felt that the cost savings would be minimal and motioned keeping Passarella.

173 Discussion ensued regarding the potential cost savings, transferring the data and the
174 qualifications of the person that has been performing the service. Mr. Christensen asked about
175 Passarella's plan to replace him. Mr. Adams stated a lower-level employee was promoted.

176 Mr. Adams noted there was a motion on the floor and asked if there was a second.
177 There was none. The motion died due to lack of a second.

178

On MOTION by Mr. Schmitt and seconded by Mr. Weinberg, with Mr. Schmitt, Mr. Weinberg, Mr. Badessa and Mr. Christensen in favor and Mr. Slater dissenting, the FL GIS Solutions, LLC Professional Services Agreement, at the rate of \$100 per hour as negotiated by Mr. Adams, was approved. [Motion passed 4-1]

179

180

181

182

183

184

185

NINTH ORDER OF BUSINESS

Continued Discussion: US 41 Traffic Signal Agreements

186

187

188

189

Mr. Cole stated an email was received approving the warrants yesterday.

190

191

192

193

194

195

196

197

198

199

200

201

202

203

204

205

206

Mr. Badessa stated he attended the CDD #2 meeting last month. He believes his research identified an issue between contract law and fairness so it will be necessary to request a copy of the contract between Publix and CDD #2. He recalled discussing this with most of those involved before Mr. Brougham's passing. In his opinion, the issues lie with how the contracts were drawn and, while CDD #1 does not have the contract between Publix and CDD #2, it has the initial 2013 contract signed by Mr. Jim Robertson, of CDD #2 and Mr. Brougham.

Mr. Badessa stated, when asked how the arrangement came about, Mr. Robertson recollected that CDDs #1 and #2 would share the net amount of any third-party contributions and Mr. Robertson stated he would not have signed an agreement stating otherwise.

Mr. Badessa recommended reviewing the Agreement based on contract law and fairness to see if CDD #1 can persuade CDD #2 to share the revenue rather than CDD #1 pursuing litigation against CDD #2.

Mr. Slater stated he was on the Board at the time of the discussions between Mr. Brougham and Mr. Robinson and he would need to review the meeting minutes. While he did not recall exact words, he thought that monies were to be evenly shared in the end. Mr. Christensen believed the 2013 contract only applied to the main gate. Mr. Adams stated the contract spoke to the future gate.

207 Mr. Badessa stated the agreement was basic and had no contingencies with no monies
208 allocated to CDD #1 and no projects were listed. In his opinion, CDD #1 in a sense participated
209 in a contract with CDD #2 without understanding there might be money or contingencies from
210 CDD #2. He felt that the initial agreement was so basic that it left a lot open to interpretation.

211 Mr. Schmitt thought part of the agreement was negotiated by Mr. DiNardo and that Mr.
212 Parisi or Mr. Albeit might have comments. It included issues with CDD #2, including driveway
213 maintenance, gatehouse access and access to Publix, to include costs associated with the traffic
214 signal. He felt the issues got conflated and stated he could not support a CDD #1 budget to bear
215 the costs identified. In his opinion, CDD #2 is taking advantage of CDD #1; it should be a shared
216 cost as CDD #1 has as much right to the money paid by Publix as the money paid by 7-Eleven.
217 He reiterated that he will not support a budget where CDD #1 pays more than CDD #2.

218 Mr. Slater thought the Board should meet with Mr. Parisi and Mr. Albeit. Mr. Parisi
219 stated he and Mr. Albeit do not represent CDD #1 or CDD #2 and suggested hiring independent
220 Counsel. Given that Mr. Pires cannot represent CDD #1 or CDD #2 in this matter because of a
221 conflict, independent Counsel could review the documents, facilitate negotiations with CDD #2
222 and explain what that the agreement means for CDD #1. Mr. Slater acknowledged the
223 suggestion. He noted Fiddler's Creek is one community and expressed concern about dividing
224 the community; however, if the CDDs cannot talk it out, he would not vote to approve it either.

225 Mr. Weinberg asked how much the gas station will contribute to the traffic light and
226 expressed his opinion that it should be a shared cost because it is not on CDD #2 property. Mr.
227 Adams stated the amount is netted out. Discussion ensued regarding the amounts contributed.
228 Mr. Adams stated both CDDs benefited from the contribution.

229 Mr. Badessa felt that it would be simple for an attorney review the contract and,
230 although he thinks there might be an issue of fairness, they are bound by contract law.

231 Mr. Parisi suggested mediation as an alternative, given the desire to focus on fairness
232 and communication. The consensus was to hire Legal Counsel.

233 This item would be included on the next agenda.

234 Discussion ensued regarding the Publix property, sale of the property that was part of
235 CDD #2, potential bond funds and the cost-splitting agreement. Mr. Slater asked how much is at
236 issue. Mr. Adams stated the total amount is \$200,000, of which CDD #1's portion would be half.

237 Mr. Weinberg supported engaging Counsel to review the contract or mediate, if it can
238 be done inexpensively. He asked for the projected timing since the warrants are issued.

239 Mr. Cole stated he had been trying to meet with Florida Department of Transportation
240 (FDOT). The estimated time for design and permitting is nine months and construction would
241 be another nine months. Six of those months are needed to order the made-to-order mast
242 arms. While the process could be sped up by ordering sooner, ordering before permit approval
243 is not advised. The entire project would take about a year and a half.

244 Mr. Weinberg noted the short turn lanes off US 41 and asked if the State or the CDD
245 would be required to extend the lanes. Mr. Cole stated that is a discussion item. Consultant Jim
246 Banks is arguing that the FDOT should pay to lengthen the turn lane that it shortened when the
247 road was expanded from two to six lanes, rather than the CDD. Mr. Cole stated Mr. Banks is
248 suggesting to the FDOT that the signal be installed before the turn lane expansion.

249

250 **TENTH ORDER OF BUSINESS**

**Status of Open Public Record on Petition to
Amend the Fiddler’s Creek Community
Development District #1 Boundaries**

251

252

253

254 Mr. Pires stated that nothing additional was filed during the open public record time.
255 The Eleventh Order of Business includes map clarifications noted by Mr. Schmitt based on maps
256 presented at the October meeting.

257 Mr. Schmitt stated, after the last meeting, he reviewed the October meeting minutes.
258 The two maps submitted showed a loss to both CDD #1 and CDD #2 to create what is shown as
259 new construction that would be a new CDD. It does not impact what was approved because the
260 transfer of land from CDD #1 to CDD #2 was approved. The point was to make it clear that the
261 document included in October is not valid and, while that map may have been considered and
262 may be considered for the future, the map does not portray what was approved. He did not
263 know if the Developer would proceed with creating another CDD in the area known as Hidden
264 Cove but he believed the record should reflect that the map dated 4/21 was not approved.

265 Mr. Pires believed that fact was clarified by Mr. Cole on the record at the October 27,
266 2021 meeting. The October 27, 2021 agenda inadvertently included two sets of maps and Mr.
267 Cole stated the 8/21 maps were the most current and the 4/21 maps were not in the petition.

268 Mr. Cole stated that is correct; the documents included in today’s agenda for the
269 Eleventh Order of Business include the 4/21 map, which was superseded by the 8/21 map.

270 Discussion ensued regarding the maps included in today’s agenda. Mr. Schmitt stated
 271 the maps labeled 5000-2 and 5000-3 are not valid and other maps in today’s agenda show
 272 future development. He felt that it is important to clarify that land transferred to CDD #2 was
 273 not tied to future development and that the maps showing future development are no longer
 274 valid because that was not approved or proposed by either CDD. Mr. Pires stated the maps with
 275 the date 4/21 were not submitted to the County for either CDD nor to the Florida Land and
 276 Water Adjudicatory Commission (FLWAC) and were not approved by the Board. The maps
 277 dated 4/21 that were in the October 27, 2021 agenda were not submitted with the application.
 278 Mr. Schmitt recalled asking specific questions at the last meeting about the intent to ensure
 279 that the area that CDD #1 gave up is not tied to future development and it would clearly be part
 280 of CDD #2. Discussion ensued regarding the previously discussed FLWAC Public Hearing
 281 tentatively set for March. Mr. Parisi believed the intention is to schedule the hearing for June,
 282 due to the election and Commission Hearings; he would give an update at the next meeting.
 283 Mr. Pires stated the land being transferred to CDD #2 is subject to County Commission approval
 284 and, upon County approval, it would be effective as of the date of the CDD #1 rule change.

285

ELEVENTH ORDER OF BUSINESS

**Discussion/Review of Boundary
Amendment Materials Presented at
October Meeting**

286
287
288
289

- **Public Hearing Date: March 23, 2022 at 8:00 A.M.**

291 This item was discussed in conjunction with the Tenth Order of Business.
 292 Mr. Weinberg stated the March 23, 2022 Public Hearing date regarding the Boundary
 293 Amendment does not apply to CDD #1. Mr. Pires stated the Public Hearing that CDD #1 would
 294 hold on that date pertains to the sidewalk rule.

295

TWELFTH ORDER OF BUSINESS

**Consideration of IberiaBank Term Sheet for
Revolving Line of Credit (Renewal)**

296
297
298

299 Mr. Adams presented the IberiaBank Term Sheet. He stated this would normally have
 300 been presented in October but IberiaBank was acquired by First Horizon National Corporation
 301 Both CDDs are now approved, contingent upon a Term Sheet. The conditions are identical to
 302 what the CDD had in the past, with the exception of the 364-day term. He suggested adjusting
 303 the term in the initial year to match the calendar year; beginning on March 1, 2022 and ending

304 on December 31, 2022 would enable an automatic renewal and the same conditions would
305 apply. Funds in the account can be used for an emergency prior to drawing on the line of credit.

306

307 **On MOTION by Mr. Schmitt and seconded by Mr. Weinberg, the IberiaBank**
308 **Term Sheet Revolving Line of Credit renewal, was approved.**

309

310

311 **THIRTEENTH ORDER OF BUSINESS**

Consideration of Resolution 2022-04, Implementing Section 190.006(3), Florida Statutes, and Requesting that the Collier County Supervisor of Elections Begin Conducting the District’s General Elections; Providing for Compensation; Setting for the Terms of Office; Authorizing Notice of the Qualifying Period; and Providing for Severability and an Effective Date

312

313

314

315

316

317

318

319

320

321 Mr. Adams presented Resolution 2022-04. He stated Seats 1 and 2, currently held by
322 Mr. Badessa and Mr. Christensen, respectively, are up for election at the November General
323 Election. This Resolution outlines the candidate qualifications, minimum age requirement,
324 terms of the offices, etc. The candidate qualifying period is June 13 through June 17, 2022.

325

326 **On MOTION by Mr. Schmitt and seconded by Mr. Weinberg, with all in favor,**
327 **Resolution 2022-04, Implementing Section 190.006(3), Florida Statutes, and**
328 **Requesting that the Collier County Supervisor of Elections Begin Conducting**
329 **the District’s General Elections; Providing for Compensation; Setting for the**
330 **Terms of Office; Authorizing Notice of the Qualifying Period; and Providing for**
331 **Severability and an Effective Date, was adopted.**

332

333

334 **FOURTEENTH ORDER OF BUSINESS**

Acceptance of Unaudited Financial Statements as of January 31, 2022

335

336

337 Mrs. Adams distributed the Financial Highlights Report. Mr. Adams presented the
338 Unaudited Financial Statements as of January 31, 2022. The financials were accepted.

339

340 **FIFTEENTH ORDER OF BUSINESS**

Approval of January 26, 2022 Public Hearing and Regular Meeting Minutes

341

342

343 Mr. Slater presented the January 26, 2022 Public Hearing and Regular Meeting Minutes.
344 Mr. Pires noted the Court Reporter Verbatim Transcription was inserted where applicable.

345 The following change was made:

346 Page 56, Line 20: Change “the kitchen” to “The Club and Spa”

347

On MOTION by Mr. Slater and seconded by Mr. Weinberg, with all in favor, the January 26, 2022 Public Hearing and Regular Meeting Minutes, as amended, were approved.

348

349

350

351

352

353

SIXTEENTH ORDER OF BUSINESS

Action/Agenda or Completed Items

354

355 Item 1: Mr. Schmitt asked if there is still a dispute about legal bills. Mr. Pires would
356 follow up.

357 Item 2: Mr. Adams stated the appeal was submitted. It was not distributed to the Board
358 due to the file size. The appeal takes the position that the Federal Emergency Management
359 Agency (FEMA) is likely misunderstanding the prior appeal responses.

360 Item 4: Mr. Parisi stated he received several documents. Mr. Adams would send a list to
361 Mr. Parisi and Mr. Pires so they can ensure all have been received.

362 Item 5: Mr. Cole understood that Mr. Minor prepared a plan for review but he has not
363 seen it; he would follow up. Discussion ensued about locating an additional stop sign 100’
364 beyond the existing stop sign and gate. The preference is for Publix to move the monument sign
365 but it was unlikely that Publix would do it.

366 Mr. Pires asked if the monument is in the Association’s right-of-way (ROW). Mr. Cole
367 replied affirmatively. The consensus was that the options are to move the monument sign or
368 install a stop sign. Mr. Cole stated a stop sign would be his recommendation; it would be in CDD
369 #2’s ROW. Mr. Pires asked if a warning sign would help. Cole and Mr. Weinberg did not believe
370 so. Mr. Weinberg thought Publix should move the sign, which he believes is on the wrong side
371 of the road. Mr. Pires asked if the County signed off on that location. Mr. Cole could not recall
372 the exact location in the approved plans. Mr. Parisi thought it would not have been installed in
373 a location that was not approved. Mr. Cole stated he emailed Mr. Minor but has not received a
374 response. Mr. Weinberg felt it is the Design Engineer’s responsibility to design in accordance
375 with line-of-sight and compliance is the applicant’s responsibility.

376 Item 11: Mr. Schmitt stated a request was filed with the County for a Temporary
377 Construction Office. Mr. Parisi stated that is correct; staff was directed to clean up the area.

378 Item 12: Mr. Cole stated the list of trees was completed and would be sent soon.

379 Item 13: This is a duplicate item and would be deleted.

380 Items 3, 6, 9 and 10 were completed.

381

382 SEVENTEENTH ORDER OF BUSINESS

Staff Reports

383

384 A. District Counsel: *Woodward, Pires and Lombardo, P.A.*

385 There was no report.

386 B. District Manager: *Wrathell, Hunt and Associates, LLC*

- 387 • NEXT MEETING DATE: March 23, 2022 at 8:00 A.M.

- 388 ○ QUORUM CHECK

389 All Supervisors confirmed their attendance at the March 23, 2022 meeting.

390 C. Operations Manager: *Wrathell, Hunt and Associates, LLC*

391 The Field Operations Report was provided for informational purposes.

392 Mrs. Adams stated the horticulturist would be put on hold. She will meet with LandCare
393 today about numerous concerns. She and Mr. Adams reviewed the property this morning and
394 noted a fertilization issue with the turf and bougainvilleas; a defective work notice would be
395 issued to LandCare today. Despite a conversation with LandCare last month, the condition has
396 not improved. GulfScapes' areas look great.

397

398 EIGHTEENTH ORDER OF BUSINESS

Landscape Advisory Committee

399

400 Ms. Benedetti provided photos of the landscaping to the Board. Mrs. Adams stated the
401 photos and the responses from the vendor were in the agenda. Ms. Benedetti expressed
402 concern about the number of dead bougainvilleas throughout. She discussed the poor
403 appearance at the Collier Boulevard entrance. Before the last meeting she sent Mrs. Adams
404 photos of weeds and two dead palms that were not addressed for six months; because the
405 dead palm trees had Ganoderma they had to be removed and could not be replaced. A
406 University of Florida Extension Center representative examined the palms, validated the
407 Ganoderma rot and recommended a horticulturist to evaluate closeup photographs at no
408 charge before engaging a horticulturist. LandCare would need to schedule an appointment.

409 Ms. Benedetti stated she received complaints about the Club Center Drive medians and
 410 she observed dead plants, debris, weeds and trash. Discussion ensued regarding possibly
 411 replacing bougainvilleas with Ixora and installing turf at endcaps, which would improve line-of-
 412 sight issues. Mr. Slater stated, while he recognized the cyclical nature, he felt that
 413 bougainvilleas are the signature plant. Ms. Benedetti stated she was only recommending
 414 replacement of some of the bougainvilleas.

415 Mrs. Adams reiterated that she would meet with LandCare and give an update at the
 416 next meeting. She asked LandCare to identify areas where the line-of-sight needs to be clear.
 417 She planned to suggest installing sod on those endcaps. While the bougainvilleas were
 418 subjected to harsh cold weather, there is also an issue with chemicals and she believed the
 419 bougainvilleas should come back. Mrs. Adams discussed LandCare’s recent staffing changes and
 420 stated she would ensure the issues are addressed.

421 Mr. Christensen asked what was recommended in the area where two palm trees were
 422 removed. Ms. Benedetti stated palm trees cannot be planted in that area for ten years;
 423 hardwoods or small shrubs are recommended. Whether to replace the trees and aesthetic
 424 alternatives were discussed. Mrs. Adams would inspect the area and make a recommendation.

425

NINETEENTH ORDER OF BUSINESS

Supervisors’ Requests

427

428 There were no Supervisors’ requests.

429

TWENTIETH ORDER OF BUSINESS

Public Comments

431

432 Mr. Elliot Miller, CDD #2 Chair, commented on the IberiaBank Term Sheet. While the
 433 Board already approved it, he suggested the Board might want to make the approval subject to
 434 any negotiations achieved by CDD #2, which has the same terms as the CDD #1 Term Sheet.

435

<p>436 On MOTION by Mr. Schmitt and seconded by Mr. Slater, the IberiaBank Term 437 Sheet Revolving Line of Credit renewal, subject to the same terms negotiated 438 by CDD #2 if the terms are better, was approved.</p>
--

439

440

TWENTY-FIRST ORDER OF BUSINESS

Adjournment

442

443 There being nothing further to discuss, the meeting adjourned at 9:58 a.m.

444

445

446

447

448

449 _____
Secretary/Assistant Secretary

Chair/Vice Chair

FIDDLER'S CREEK
COMMUNITY DEVELOPMENT DISTRICT
#1

15

FIDDLER'S CREEK CDD #1

0 #	MTG DATE ADDED TO LIST	ACTION	ACTION/AGENDA or COMPLETED ITEM	ONGOING	POSSIBLY COMPLETED BEFORE NEXT MTG	COMPLETED	MTG DATE MOVED TO COMPLETED
1	03.27.18	ACTION	Per Mr. Brougham, Ms. Lord to request that the District receive a status report on its boundary legal bills. As of 10.24.18 , Mr. Pires working with Ms. Lord to resolve a few items. As of 12.09.20 , Mr. Pires to speak with Mr. Parisi regarding reimbursement of District legal costs. 05.26.21 Mr. Pires to pursue settlement offer and discuss with Mr. Parisi. 02.23.22 Mr. Pires to follow up on this item.	X			
2	08.26.20	ACTION	Mr. Adams to draft FEMA request and send to Congressmen/women, Senators and Representatives as appropriate. 08.25.21 Scheduling conference call for next week; updates to follow. 09.22.21 Mr. Adams discussed conversations with FEMA and State Representative, FEMA returned item to the State due to a technicality, they are working on clarifying and submitting item back to FEMA. 12.08.21 Mr. Adams is waiting for a new determination memo on two of the three claims. The certified copy would be sent in the mail. No determination on the third claim was made. Further updates would be provided.	X			
3	09.22.21	ACTION	Mr. Parisi to send Mr. Pires a link to access the warranty documents for the guardhouses and Fiddler's Creek Parkway. 02.23.22 Mr. Adams to send a list of documents to Mr. Pires	X			
4	10.27.21	ACTION	Mr. Cole to have GradyMinor determine if the Publix sign was installed to code, due to line-of-sight issues. 12.08.21 Line of sight issues exiting the gatehouse not addressed; to be discussed in the CDD #2 meeting. 02.23.22 Mr. Cole to follow up on this item.	X			
5	10.27.21	ACTION/AGENDA	Mr. Cole presented quotes using two methods to repair pipes and discuss with Contractor if installing pressure relief valves was an option to prevent further irrigation breaks/hammer incidents. 12.08.21 Proposal in progress; pending additional information. 01.26.22 This would be a future Agenda Item.	X			
6	12.08.21	ACTION	Mr. Cole to review the 4 affected Mulberry Lane properties and advise Mr. Adams. Mr. Adams to send Public Hearing Notice to Ron Albeit to e-blast to residents. Field Supervisor to identify other areas that may need immediate attention including root treatment. 02.23.22 Send e-blast again.	X	X		
7	01.26.22	ACTION	Mr. Parisi to address unsightly parcel of land formerly used as the Design Center. 02.23.22 Still looks bad. Ongoing.	X			

FIDDLER'S CREEK CDD #1

O #	MTG DATE ADDED TO LIST	ACTION	ACTION/AGENDA or COMPLETED ITEM	ONGOING	POSSIBLY COMPLETED BEFORE NEXT MTG	COMPLETED	MTG DATE MOVED TO COMPLETED
8	01.26.22	ACTION/AGENDA	Mr. Cole to prepare a spreadsheet and a map showing addresses with trees between the valley gutters and sidewalks.	X	X		
9	02.23.22	ACTION	SOLitude to review and include an update in her report and address green color of Lake 34A adjacent to Runaway Bay.	X			
10	02.23.22	ACTION	Mrs. Adams to address the need for a street sweeper in Mahogany Bend.	X			
11	02.23.22	ACTION	Mr. Cole to compile the addresses of additional homes requiring valley gutter repairs on Mulberry Lane and have the areas in question inspected. To be on the next meeting agenda.	X			
12	02.23.22	ACTION	Mr. Slater to review Meeting Minutes from 2013 for references to the contract between CDD #1 and CDD #2.	X			
13	02.23.22	ACTION	Mr. Pires to contact potential candidates to review documents and/or facilitate negotiations with CDD #2; to be presented on the next agenda.	X			
14	02.23.22	ACTION	Mr. Parisi to advise regarding the date for the FLWAC Public Hearing.	X			
15	02.23.22	ACTION	Mr. Adams to request adjustment of the IberiaBank Revolving Line of Credit Term to match up with the calendar year.	X			
16	02.23.22	ACTION	Mrs. Adams to meet with LandCare and issue a Defective Work Notice and provide an update at the next meeting.	X	X		

**FIDDLER'S CREEK
COMMUNITY DEVELOPMENT DISTRICT
#1**

16B

FIDDLER'S CREEK COMMUNITY DEVELOPMENT DISTRICT #1

BOARD OF SUPERVISORS FISCAL YEAR 2021/2022 MEETING SCHEDULE

LOCATION

Fiddler's Creek Club and Spa, 3470 Club Center Boulevard, Naples, Florida 34114

DATE	POTENTIAL DISCUSSION/FOCUS	TIME
October 27, 2021	Regular Meeting	8:00 AM
<i>The Rookery at Marco Golf Club, 3433 Club Center Drive, Naples, Florida, 34114</i>		
Join Zoom Meeting https://us02web.zoom.us/j/83356980751 Meeting ID: 833 5698 0751 Dial by your location 929 205 6099 US Meeting ID: 833 5698 0751		
December 8, 2021*	Regular Meeting	8:00 AM
January 26, 2022	Regular Meeting	8:00 AM
February 23, 2022	Regular Meeting	8:00 AM
March 23, 2022	Regular Meeting	8:00 AM
April 27, 2022	Regular Meeting	8:00 AM
May 25, 2022	Regular Meeting	8:00 AM
June 22, 2022	Regular Meeting	8:00 AM
July 27, 2022	Regular Meeting	8:00 AM
August 24, 2022	Public Hearing & Regular Meeting	8:00 AM
September 28, 2022	Regular Meeting	8:00 AM

***Exceptions**

December meeting date is two weeks earlier to accommodate Christmas Holiday